

# CR, CRI, CRN, CRE, CRIE, CRNE

Vertical multistage centrifugal pumps  
50 Hz



# Contents

## Product data

Introduction	3
Performance range - CR, CRI, CRN	4
Performance range - CRE, CRIE, CRNE	4
Applications	5
Product range	6
Pump	7
Motor	7
Terminal box positions	8
Ambient temperature	8
Viscosity	8

## Control of E-pumps

Examples of E-pump applications	9
Central management system	10
Remote control	10
Control panel	10
Control modes for E-pumps	11
CRE, CRIE, CRNE with integrated pressure sensor	11
CRE, CRIE and CRNE without sensor	11

## Construction

CR(E) 1s, 1, 3, 5, 10, 15 and 20	12
CRI(E), CRN(E) 1s, 1, 3, 5, 10, 15 and 20	12
CR(E) 32, 45, 64 and 90	13
CRN(E) 32, 45, 64 and 90	13
Type keys	14

## Operating and inlet pressures

Maximum operating pressure and temperature range	15
Operating range of the shaft seal	15
Maximum inlet pressure	16

## Selection and sizing

Selection of pumps	17
How to read the curve charts	21
Guidelines to performance curves	21

## Performance curves

### Technical data

CR 1s	22
CRI, CRN 1s	24
CR, CRE 1	26
CRI, CRN, CRIE, CRNE 1	28
CR, CRE 3	30
CRI, CRN, CRIE, CRNE 3	32
CR, CRE 5	34
CRI, CRN, CRIE, CRNE 5	36
CRI, CRN, CRIE, CRNE 10	40
CR, CRE 15	42
CRI, CRN, CRIE, CRNE 15	44
CR, CRE 20	46
CRI, CRN, CRIE, CRNE 20	48
CRN, CRNE 64	60
CR, CRE 90	62
CRN, CRNE 90	64

### Motor data

Standard motors for CR, CRI, CRN, 50 Hz	66
E-motors for CRE, CRIE, CRNE, 50 Hz	67

### Pumped liquids

Pumped liquids	68
List of pumped liquids	68

### Accessories

Pipework connection	70
Counter flanges for CR(E)	70
Counter flanges for CRN(E)	72
PJE couplings for CRN(E)	74
FlexiClamp base connections	74
Potentiometer for CRE, CRIE, CRNE	77
G10-LON interface for CRE, CRIE, CRNE	77
LiqTec for CR(E), CRI(E) and CRN(E)	77
Remote control, R100	77
EMC-filter for CRE, CRIE, CRNE	77
Sensors for CRE, CRIE, CRNE	78

### Variants

Lists of variants - on request	79
--------------------------------	----

### Further product documentation

WinCAPS	80
WebCAPS	81

## Introduction

This data booklet deals with CR, CRI and CRN as well as CRE, CRIE and CRNE pumps.



GR5381

**Fig. 1** CR, CRI and CRN pumps

CR, CRI and CRN pumps are vertical multistage centrifugal pumps. The in-line design enables the pump to be installed in a horizontal one-pipe system where the suction and discharge ports are in the same horizontal plane and have the same pipe dimensions. This design provides a more compact pump design and pipework.

Grundfos CR pumps come with various pump sizes and various numbers of stages to provide the flow and the pressure required.

CR pumps are suitable for a variety of applications from pumping of potable water to pumping of chemicals. The pumps are therefore used in a wide diversity of pumping systems where the performance and material of the pump meet specific demands.

The CR pumps consist of two main components: The motor and the pump unit. The motor of CR pumps is a Grundfos motor designed to EN standards.

The pump unit consists of optimised hydraulics, various types of connections, an outer sleeve, a pump head and various other parts.

CR pumps are available in various material versions according to the pumped liquid.

## CRE, CRIE, CRNE pumps



TM02 7397 3403

**Fig. 2** CRE, CRIE and CRNE pumps

CRE, CRIE and CRNE pumps are built on the basis of CR, CRI, CRN pumps.

CRE, CRIE and CRNE pumps belong to the so-called E-pump family. CRE, CRIE and CRNE pumps are referred to as E-pumps.

The difference between the CR and the CRE pump range is the motor. CRE, CRIE and CRNE pumps are fitted with an E-motor, i.e. a motor with built-in frequency control.

The motor of the CRE pump is a Grundfos MGE or MMGE motor designed to EN standards.

Frequency control enables continuously variable control of motor speed, which makes it possible to set the pump to operation at any duty point. The aim of continuously variable control of the motor speed is to adjust the performance to a given requirement.

CRE, CRIE and CRNE pumps are available with an integrated pressure sensor connected to the frequency control.

The pump materials are the same as those of the CR, CRI and CRN pump range.

### Selecting a CRE pump

Select a CRE pump if:

- controlled operation is required, i.e. consumption fluctuates,
- constant pressure is required,
- communication with the pump is required.

Adaptation of performance through frequency-controlled speed control offers obvious advantages:

- Energy savings.
- Increased comfort.
- Control and monitoring of the pump performance.

## Performance range - CR, CRI, CRN

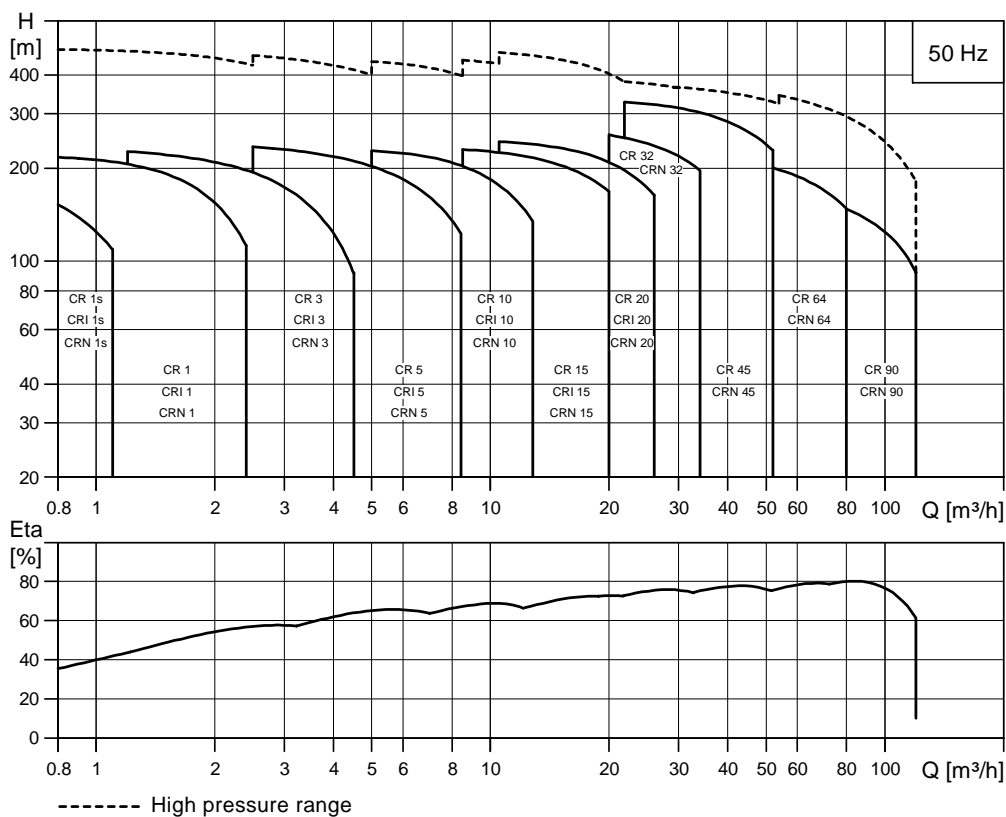

TM02 1192 3605

## Performance range - CRE, CRIE, CRNE

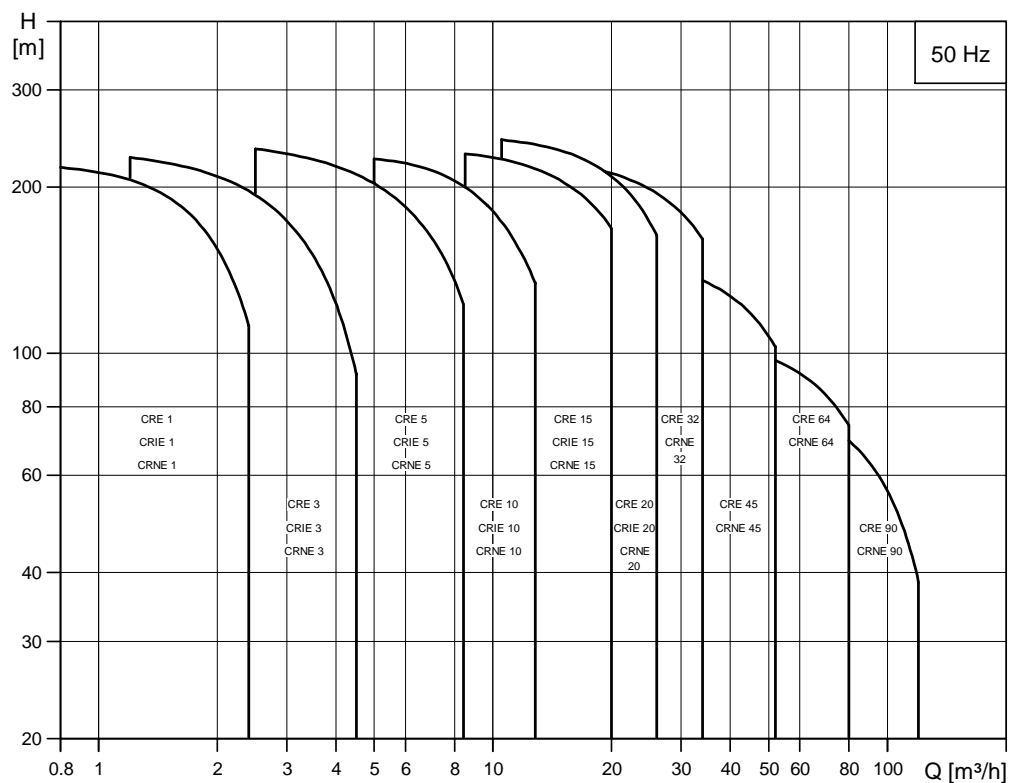

TM02 7281 3605

## Applications

Application	CR, CRI	CRN	CRE, CRNE
<b>Water supply</b>			
Filtration and transfer at waterworks	●	○	●
Distribution from waterworks	●	○	●
Pressure boosting in mains	●	○	●
Pressure boosting in high-rise buildings, hotels, etc.	●	○	●
Pressure boosting for industrial water supply	●	○	●
<b>Industry</b>			
<b>Pressure boosting in...</b>			
process water systems	●	●	●
washing and cleaning systems	●	●	○
vehicle washing tunnels	●	○	●
fire fighting systems	●		○
<b>Liquid transfer in...</b>			
cooling and air-conditioning systems (refrigerants)	●	○	●
boiler feed and condensate systems	●	○	●
machine tools (cooling lubricants)	●	●	●
aquafarming★	●	○	
<b>Transfer of...</b>			
oils and alcohols	●	●	
acids and alkalis★		●	
glycol and coolants	●		
<b>Water treatment</b>			
Ultra-filtration systems		●	
Reverse osmosis systems★		●	
Softening, ionising, demineralizing systems		●	
Distillation systems		●	
Separators	●	●	●
Swimming baths★		●	
<b>Irrigation</b>			
Field irrigation (flooding)	●	○	
Sprinkler irrigation	●	○	●
Drip-feed irrigation	●	○	

● Recommended version.

○ Alternative version.

★ CRT, CRTE version available. For further information about CRT, CRTE pumps see, "Pumped liquids" page 68 or related CRT, CRTE data booklet.

## Product range

Range	CR 1s	CR, CRE 1	CR, CRE 3	CR, CRE 5	CR, CRE 10	CR, CRE 15	CR, CRE 20	CR, CRE 32	CR, CRE 45	CR, CRE 64	CR, CRE 90	
Nominal flow rate [m <sup>3</sup> /h]	0.8	1	3	5	10	15	20	32	45	64	90	
Temperature range [°C]	-20 to +120							-30 to +120				
Temperature range [°C] – on request	-40 to +180							-40 to +180				
Max. pump efficiency [%]	35	48	58	66	70	72	72	78	79	80	81	
<b>CR pumps</b>												
Flow range [m <sup>3</sup> /h]	0.3-1.1	0.7-2.4	1.2-4.5	2.5-8.5	5-13	9-24	11-29	15-40	22-58	30-85	45-120	
Max. pressure [bar]	21	22	24	24	22	23	25	28	26	20	20	
High pressure [bar] – on request	-	47	47	47	47	47	47	39	40	39	39	
Motor power [kW]	0.37-1.1	0.37-2.2	0.37-3	0.37-5.5	0.37-7.5	1.1-15	1.1-18.5	1.5-30	3-45	4-45	5.5-45	
<b>CRE pumps</b>												
Flow range [m <sup>3</sup> /h]	-	0.7-2.4	1.2-4.5	2.5-8.5	5-13	8.5-23.5	10.5-29	15-40	22-58	30-85	45-120	
Max. pressure [bar]	-	22	24	24	22	23	25	28	26	20	20	
Motor power [kW]	-	0.37-2.2	0.37-3	0.37-5.5	0.37-7.5	1.1-15	1.1-18.5	1.5-22	3-22	4-22	5.5-22	
<b>Version</b>												
CR, CRE: Cast iron and stainless steel EN 1.4301/AISI 304	•	•	•	•	•	•	•	•	•	•	•	
CRI, CRIE: Stainless steel EN 1.4301/AISI 304	•	•	•	•	•	•	•	-	-	-	-	
CRN, CRNE: Stainless steel EN 1.4401/AISI 316	•	•	•	•	•	•	•	•	•	•	•	
CRT, CRTE: Titanium	See the CRT, CRTE data booklet.											
<b>CR, CRE pipe connection</b>												
Oval flange (BSP)	Rp 1	Rp 1	Rp 1	Rp 1¼	Rp 1½	Rp 2	Rp 2	-	-	-	-	
Oval flange (BSP) – on request	Rp 1¼	Rp 1¼	Rp 1¼	Rp 1	Rp 1¼ Rp 2	Rp 2½	Rp 2½	-	-	-	-	
Flange	DN 25/ DN 32	DN 25/ DN 32	DN 25/ DN 32	DN 25/ DN 32	DN 40	DN 50	DN 50	DN 65	DN 80	DN 100	DN 100	
Flange – on request	-	-	-	-	DN 50	-	-	DN 80	DN 100	DN 125	DN 125	
<b>CRI, CRIE pipe connection</b>												
Oval flange (BSP)	Rp 1	Rp 1	Rp 1¼	Rp 1¼	Rp 1½	Rp 2	Rp 2	-	-	-	-	
Oval flange (BSP) – on request	Rp 1¼	Rp 1¼	Rp 1	Rp 1	Rp 2	-	-	-	-	-	-	
Flange	DN 25/ DN 32	DN 25/ DN 32	DN 25/ DN 32	DN 25/ DN 32	DN 40	DN 50	DN 50	-	-	-	-	
Flange – on request	-	-	-	-	DN 50	-	-	-	-	-	-	
PJE coupling (Victaulic)	R 1¼ DN 32	R 1¼ DN 32	R 1¼ DN 32	R 1¼ DN 32	R 2 DN 50	R 2 DN 50	R 2 DN 50	-	-	-	-	
Clamp coupling (L-coupling)	ø48.3	ø48.3	ø48.3	ø48.3	ø60.3	ø60.3	ø60.3	-	-	-	-	
Union (+GF+)	G 2	G2	G 2	G 2	G 2¼	G 2¼	G 2¼	-	-	-	-	
<b>CRN(E) pipe connection</b>												
Oval flange (BSP)	Rp 1	Rp 1	Rp 1¼	Rp 1¼	Rp 1½	Rp 2	Rp 2	-	-	-	-	
Oval flange (BSP) – on request	Rp 1¼	Rp 1¼	Rp 1	Rp 1	Rp 2	-	-	-	-	-	-	
Flange	DN 25/ DN 32	DN 25/ DN 32	DN 25/ DN 32	DN 25/ DN 32	DN 40	DN 50	DN 50	DN 65	DN 80	DN 100	DN 100	
Flange – on request	-	-	-	-	DN 50	-	-	DN 80	DN 100	DN 125	DN 125	
PJE coupling (Victaulic)	R 1¼ DN 32	R 1¼ DN 32	R 1¼ DN 32	R 1¼ DN 32	R 2 DN 50	R 2 DN 50	R 2 DN 50	R 3 <sup>1)</sup>	R 4 <sup>1)</sup>	R 4 <sup>1)</sup>	R 5 <sup>1)</sup>	
Clamp coupling (L-coupling)	ø48.3	ø48.3	ø48.3	ø48.3	ø60.3	ø60.3	ø60.3	-	-	-	-	
Union (+GF+)	G 2	G2	G 2	G 2	G 2¼	G 2¼	G 2¼	-	-	-	-	

1) On request

## Pump

The CR and CRE pumps are non-self-priming, vertical multistage centrifugal pumps.

The pumps are available with a Grundfos standard motor (CR pumps) or a frequency-controlled motor (CRE pumps).

The pump consists of a base and a pump head. The chamber stack and the outer sleeve are secured between the pump head and the base by means of staybolts. The base has suction and discharge ports on the same level (in-line). All pumps are equipped with a maintenance-free mechanical shaft seal of the cartridge type.

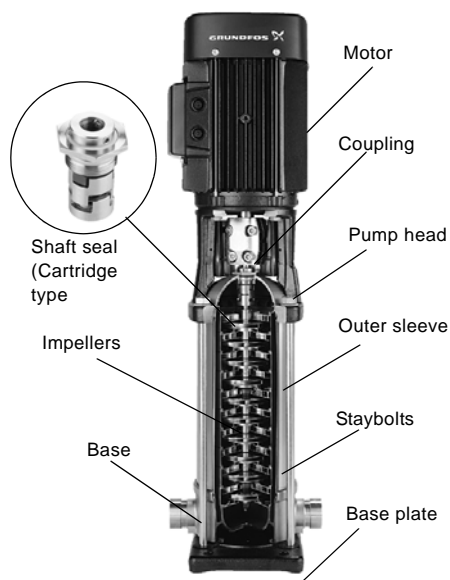

GR5357 - GR3395

Fig. 3 CR pump

## Motor

### Grundfos standard motors - MG and Siemens motors

CR, CRI and CRN pumps are fitted with a totally enclosed, fan-cooled, 2-pole Grundfos standard motor with principal dimensions in accordance with the EN standards.

Electrical tolerances according to EN 60034.

From 0.37 to 2.2 kW Grundfos offers CR pumps fitted with single-phase MG motors (1 x 220-230/240 V).

### Frequency-controlled motors - MGE

CRE, CRIE and CRNE pumps are fitted with a totally enclosed, fan-cooled, 2-pole frequency-controlled motor with principal dimensions in accordance with the EN standards.

Electrical tolerances according to EN 60034.

From 0.37 to 1.1 kW Grundfos offers CRE pumps fitted with single-phase MGE motors (1 x 200-240 V).

## Electrical data

### CR, CRI, CRN pumps

	MG motor
<b>Mounting designation</b>	Up to 4 kW: V 18 From 5.5 kW: V 1
<b>Insulation class</b>	F
<b>Efficiency class</b>	EFF 1 (0.37-0.75 kW and 3 kW are EFF 2)
<b>Enclosure class</b>	IP 55★
<b>Supply voltage</b> (Tolerance: ±10%)	P <sub>2</sub> : 0.37-1.5 kW: 3 x 220-240/380-415 V, 50 Hz  P <sub>2</sub> : 2.2-45 kW: 3 x 380-415, 50 Hz
<b>Supply frequency</b>	50 Hz

★ IP 44, IP 54 and IP 65 - on request.

### CRE, CRIE, CRNE pumps

	MGE motor (P <sub>2</sub> ≤ 7.5 kW)	MGE motor (P <sub>2</sub> ≥ 11-22 kW)
<b>Mounting designation</b>	Up to 4 kW: V 18 From 5.5 kW: V 1	
<b>Insulation class</b>	F	
<b>Efficiency class</b>	EFF 1★	EFF 2
<b>Enclosure class</b>	IP 54	
<b>Supply voltage</b> (Tolerance: ±10%)	P <sub>2</sub> : 0.37-1.1 kW: 1 x 200-240 V  P <sub>2</sub> : 0.75-7.5 kW: 3 x 380-480 V	P <sub>2</sub> : 11-22 kW: 3 x 380-415 V
<b>Supply frequency</b>	50/60 Hz	

★ Single-phase MGE motors are EFF 2.

## Optional motors

The Grundfos standard range of motors covers a wide variety of application demands. However, for special applications or operating conditions, custom-built motor solutions can be provided.

For special applications or operating conditions, Grundfos offers custom-built motors such as:

- ATEX approved motors,
- MG motors with anti-condensation heating unit,
- motors with thermal protection.

## Motor protection

### MG and Siemens motors

Single-phase Grundfos motors have a built-in thermal overload switch (IEC 34-11: TP 211).

Three-phase motors **must** be connected to a motor starter in accordance with local regulations.

Three-phase Grundfos motors from 3 kW and upwards have a built-in thermistor (PTC) according to DIN 44 082 (IEC 34-11: TP 211).

### MGE motors

CRE, CRIE, CRNE pumps require no external motor protection. The MGE motor incorporates thermal protection against slow overloading and blocking (IEC 34-11: TP 211).

## Terminal box positions

As standard the terminal box is mounted on the suction side of the pump.

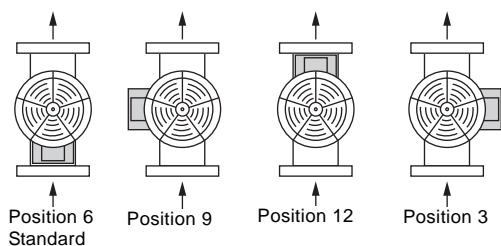

Fig. 4 Terminal box positions

TM02 18 05 2001

## Ambient temperature

0.37-0.75 kW motors (EFF 2, MG): Max. +40°C.

1.1-11 kW motors (EFF 1, MG): Max. +60°C.

15-45 kW motors (EFF 1, Siemens): Max. +55°C.

If the ambient temperature exceeds above maximum values or if the motor is located 1000 metres above sea level, the motor output (P2) must be reduced due to the low density and consequently low cooling effect of the air. In such cases, it may be necessary to use a motor with a higher rated output.

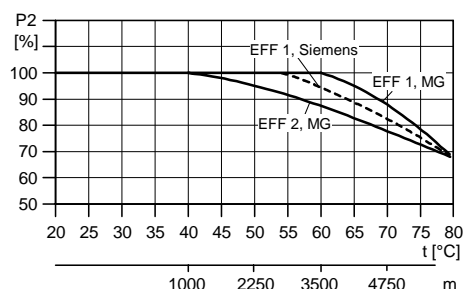

TM03 1868 3305

Fig. 5 Relationship between motor output (P2) and ambient temperature

## Viscosity

The pumping of liquids with densities or kinematic viscosities higher than those of water will cause a considerable pressure drop, a drop in the hydraulic performance and a rise in the power consumption.

In such situations the pump should be equipped with a larger motor. If in doubt, contact Grundfos.



## Examples of E-pump applications

CRE, CRIE and CRNE pumps are the ideal solution in a number of applications characterized by a need for variable flow at constant pressure. The pumps are suited for water supply systems and pressure boosting, but also industrial applications.

Depending on the nature of the application, the pumps offer energy-savings, increased comfort and improved processing.

### E-pumps in the service of industry

Industry uses a large number of pumps in many different applications. Demands on pumps in terms of pump performance and mode of operation make speed control a must in many applications.

Below is mentioned some of the applications in which E-pumps are often used.

#### Constant pressure

- Water supply,
- Washing and cleaning systems,
- Distribution from waterworks,
- Humidifying systems,
- Water treatment systems,
- Process boosting systems, etc.

**Example:** Within industrial water supply, E-pumps with integrated pressure sensor are used to ensure a constant pressure in the piping network. From the sensor, the E-pump receives inputs about changes of pressure as a result of changes in the consumption. The E-pump responds to the input by adjusting the speed until the pressure is equalized. The constant pressure is stabilized once more on the basis of a preset setpoint.

#### Constant temperature

- Air-conditioning systems at industrial plants,
- Industrial cooling systems,
- Industrial freezing systems,
- Casting and moulding tools, etc.

**Example:** In industrial freezing systems, E-pumps with temperature sensor increase comfort and lower operating costs compared with pumps without a temperature sensor.

An E-pump continuously adapts its performance to the changing demands reflected in the differences in temperature of the liquid circulating in the freezing system. Thus, the lower the demand for cooling, the smaller the quantity of liquid circulated in the system and vice versa.

#### Constant flow

- Steam boiler systems,
- Condensate systems,
- Sprinkler irrigation systems,
- Chemical industry, etc.

**Example:** In a steam boiler, it is important to be able to monitor and control pump operation to maintain a constant level of water in the boiler.

By using an E-pump with level sensor in the boiler, it is possible to maintain a constant water level.

A constant water level ensures optimum and cost-efficient operation as a result of a stable steam production.

#### Dosing applications

- Chemical industry (i.e. control of pH-values),
- Petrochemical industry,
- Paint industry,
- Degreasing systems,
- Bleaching systems, etc.

**Example:** In the petrochemical industry, E-pumps with pressure sensor are used as dosing pumps. The E-pumps help to ensure that the correct mixture ratio is achieved when more liquids are combined.

E-pumps functioning as dosing pumps improve processing and offer energy-savings.

#### E-pumps in commercial building services

Commercial building services use E-pumps to maintain a constant pressure or a constant temperature based on a variable flow.

#### Constant pressure

- Water supply in high-rise buildings i.e. office buildings, hotels, etc.

**Example:** E-pumps with pressure sensor are used for water supply in high-rise buildings to ensure a constant pressure even at the highest draw-off point. As the consumption pattern and thus the pressure changes during the day, the E-pump continuously adapts its performance until the pressure is equalized.

#### Constant temperature

- Air-conditioning systems in hotels, schools,
- Building cooling systems, etc.

**Example:** E-pumps are an excellent solution in buildings where constant temperature is essential. E-pumps keep the temperature constant in air-conditioned high-rise glass buildings, irrespective of the seasonal fluctuations of the out-door temperature, and various heat impacts inside the building.

## Control options of E-pumps

Communication with CRE, CRIE, CRNE pumps is possible by means of

- a central management system,
- remote control (Grundfos R100) or
- a control panel.

The purpose of controlling an E-pump is to monitor and control the pressure, temperature, flow and liquid level of the system.

## Central management system

Communication with the E-pump is possible even though the operator is not present near the E-pump. Communication is enabled by having connected the E-pump to a central management system allowing the operator to monitor and change control modes and setpoint settings of the E-pump.

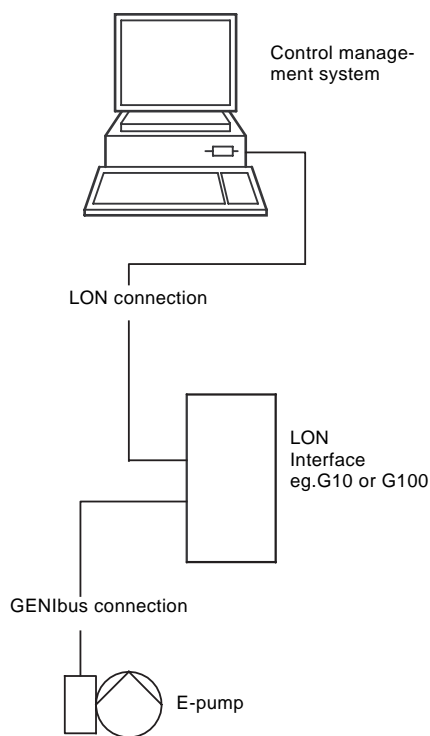

Fig. 6 Structure of a central management system

TM02 6592 1404

## Remote control

The R100 remote control produced by Grundfos is available as an accessory.

The operator communicates with the E-pump by pointing the IR-signal transmitter at the control panel of the E-pump terminal box.

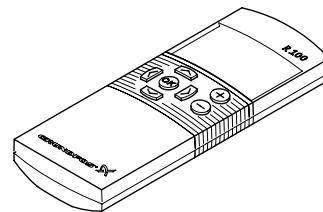

TM00 4498 2802

Fig. 7 R100 remote control

On the R100 display it is possible to monitor and change control modes and settings of the E-pump.

## Control panel

The control panel of the E-pump terminal box makes it possible to change the setpoint settings manually.

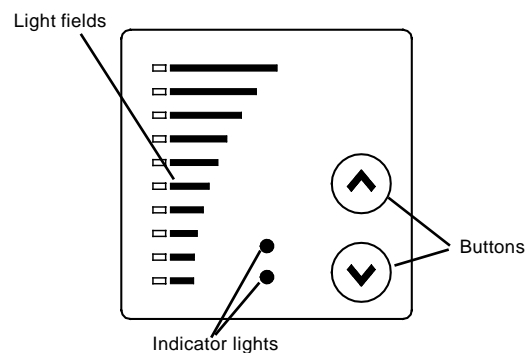

TM00 7600 0404

Fig. 8 Control panel on CRE pump

## Control modes for E-pumps

Grundfos offers CRE, CRIE and CRNE pumps in two different variants:

- CRE, CRIE and CRNE with integrated pressure sensor
- CRE, CRIE and CRNE without sensor.

### CRE, CRIE, CRNE with integrated pressure sensor

CRE, CRIE and CRNE pumps with integrated pressure sensor are suitable for applications where you want to control the pressure after the pump, irrespective of the flow. For further information, see the section "Examples of E-pump applications" page 9.

Signals of pressure changes in the piping system are transmitted continuously from the sensor to the pump. The pump responds to the signals by adjusting its performance up or down to compensate for the pressure difference between the actual and the desired pressure. As this adjustment is a continuous process, a constant pressure is maintained in the piping system.



TM02 7398 3403

Fig. 9 CRE, CRIE and CRNE pumps

A CRE, CRIE or CRNE pump with integrated pressure sensor facilitates installation and commissioning.

CRE, CRIE and CRNE pumps with integrated pressure sensor can be set to:

- constant-pressure mode (factory setting) or
- constant-curve mode.

In **constant-pressure** mode, the pump maintains a preset pressure after the pump, irrespective of the flow, see figure below.

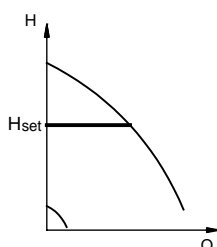

TM00 9322 4796

Fig. 10 Constant pressure mode

In **constant-curve** mode, the pump is not controlled. It can be set to pump according to a preset pump characteristic within the range from min. curve to max. curve, see figure below.

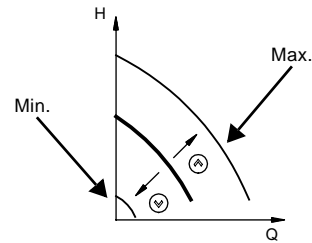

TM00 9323 1204

Fig. 11 Constant curve mode

### CRE, CRIE and CRNE without sensor

CRE, CRIE and CRNE pumps without sensor are suitable for applications where

- uncontrolled operation is required
- you want to fit another sensor later in order to control the flow, temperature, differential temperature, liquid level, pH value, etc at some arbitrary point in the system.

CRE, CRIE and CRNE pumps without sensor can be set to:

- controlled-operation mode or
- uncontrolled-operation mode (factory-setting).

In **controlled**-operation mode, the pump adjusts its performance to the desired setpoint, see figure below.

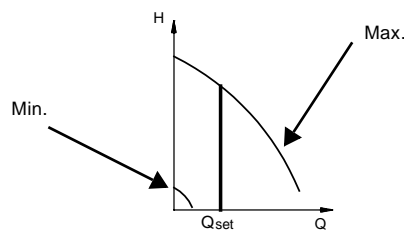

TM02 7264 2803

Fig. 12 Constant flow mode

In **uncontrolled**-operation mode, the pump operates according to the constant curve set, see figure below.

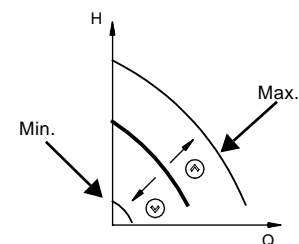

TM00 9323 1204

Fig. 13 Constant curve mode

CRE, CRIE and CRNE pumps can be fitted with sensor types meeting the requirements mentioned in the data booklet titled "Grundfos E-pumps".

## CR(E) 1s, 1, 3, 5, 10, 15 and 20



TM02 1198 0601 - GR7377 - GR7379

### Sectional drawing

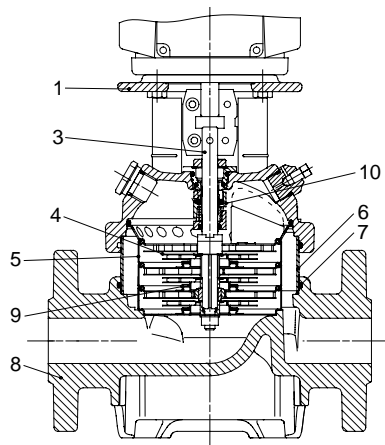

TM02 1194 1403

### Materials: CR(E)

Pos.	Designation	Materials	EN/DIN	AISI/ASTM
1	Pump head	Cast iron EN-GJL-200	EN-JL1030	ASTM 25B
3	Shaft	Stainless steel	1.4401	AISI 316 AISI 431
4	Impeller	Stainless steel	1.4301	AISI 304
5	Chamber	Stainless steel	1.4301	AISI 304
6	Outer sleeve	Stainless steel	1.4301	AISI 304
7	O-ring for outer sleeve	EPDM or FKM		
8	Base	Cast iron EN-GJL-200	EN-JL1030	ASTM 25B
9	Neck ring	PTFE		
10	Shaft seal			
	Rubber parts	EPDM or FKM		

## CRI(E), CRN(E) 1s, 1, 3, 5, 10, 15 and 20



TM02 1808 2001 - GR7373 - GR7375

### Sectional drawing

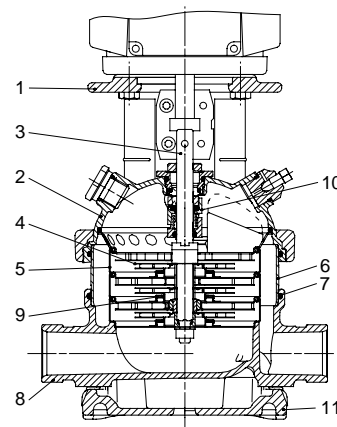

TM02 1195 1403

### Materials: CRI(E), CRN(E)

Pos.	Designation	Materials	EN/DIN	AISI/ASTM
1	Pump head	Cast iron EN-GJL-200 <sup>1)</sup>	EN-JL1030	ASTM 25B
2	Pump head cover	Stainless steel	1.4408	CF 8M eq. to AISI 316
3	Shaft	Stainless steel	1.4401 <sup>2)</sup> 1.4460 <sup>3)</sup>	AISI 316 AISI 329
8	Base	Stainless steel	1.4408	CF 8M eq. to AISI 316
9	Neck ring	PTFE		
10	Shaft seal	Cartridge type		
11	Base plate	Cast iron EN-GJL-200 <sup>1)</sup>	EN-JL1030	ASTM 25B
	Rubber parts	EPDM or FKM		
<b>CRI(E)</b>				
4	Impeller	Stainless steel	1.4301	AISI 304
5	Chamber	Stainless steel	1.4301	AISI 304
6	Outer sleeve	Stainless steel	1.4301	AISI 304
7	O-ring for outer sleeve	EPDM or FKM		
<b>CRN(E)</b>				
4	Impeller	Stainless steel	1.4401	AISI 316
5	Chamber	Stainless steel	1.4401	AISI 316
6	Outer sleeve	Stainless steel	1.4401	AISI 316
7	O-ring for outer sleeve	EPDM or FKM		

- <sup>1)</sup> Stainless steel available on request.
- <sup>2)</sup> CRI(E), CRN(E) 1S, 1, 3, 5
- <sup>3)</sup> CRI(E), CRN(E) 10, 15, 20

## CR(E) 32, 45, 64 and 90



TM01 2150 1298 - GR5952

## CRN(E) 32, 45, 64 and 90



TM02 7399 3403

### Sectional drawing

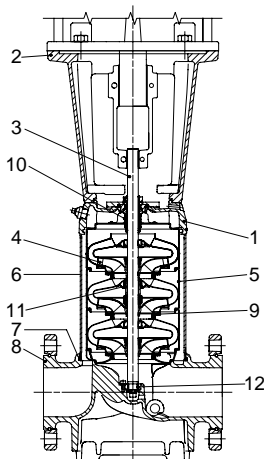

TM01 1836 1403

### Sectional drawing

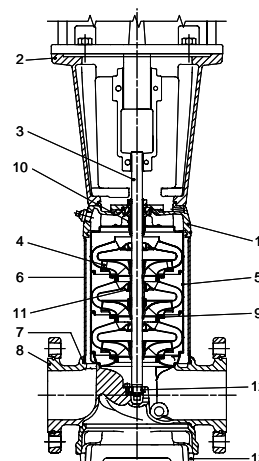

TM01 1837 1403

### Materials: CR(E)

Pos.	Designation	Materials	EN/DIN	AISI/ASTM
1	Pump head	Cast iron EN-GJS-500-7	EN-JS1050	ASTM 80-55-06
2	Motor stool	Cast iron EN-GJL-200	EN-JL1030	ASTM 25B
3	Shaft	Stainless steel	1.4057	AISI 431
4	Impeller	Stainless steel	1.4301	AISI 304
5	Chamber	Stainless steel	1.4301	AISI 304
6	Outer sleeve	Stainless steel	1.4301	AISI 304
7	O-ring for outer sleeve	EPDM or FKM		
8	Base	Cast iron EN-GJS-500-7	EN-JS1050	ASTM 80-55-06
9	Neck ring	Carbon-graphite filled PTFE		
10	Shaft seal			
11	Bearing ring	Bronze		
12	Bottom bear- ing ring	Tungsten car- bide/Tungsten carbide		
	Rubber parts	EPDM or FKM		

### Materials: CRN(E)

Pos.	Designation	Materials	EN/DIN	AISI/ASTM
1	Pump head	Stainless steel	1.4408	CF 8M eq. to AISI 316
2	Motor stool	Cast iron EN-GJL-200 1)	EN-JL1030	ASTM 25B
3	Shaft	Stainless steel	1.4462	
4	Impeller	Stainless steel	1.4401	AISI 316
5	Chamber	Stainless steel	1.4401	AISI 316
6	Outer sleeve	Stainless steel	1.4401	AISI 316
7	O-ring for outer sleeve	EPDM or FKM		
8	Base	Stainless steel	1.4408	CF 8M eq. to AISI 316
9	Neck ring	Carbon-graphite filled PTFE		
10	Shaft seal			
11	Bearing ring	Carbon-graphite filled PTFE		
12	Bottom bear- ing ring	Tungsten car- bide/Tungsten carbide		
13	Base plate	Cast iron EN-GJS-500-7 <sup>1)</sup>	EN-JS1050	ASTM 88-55-06
	Rubber parts	EPDM or FKM		

1) Stainless steel available on request.

## Type keys

### CR(E), CRI(E), CRN(E)

Example	CR E 32 (s) -4 -2 -A -F -G -E -HQQE
Type range: CR, CRI, CRN	
Pump with integrated frequency control	
Flow rate [m <sup>3</sup> /h]	
All impellers with reduced diameter (applies only to CR, CRI, CRN 1s)	
Number of impellers	
Number of reduced-diameter impellers (CR(E), CRN(E) 32, 45, 64, 90)	
Code for pump version	
Code for pipe connection	
Code for materials	
Code for rubber parts	
Code for shaft seal	

## Codes

Example	A	-F	-A	-E	-H	QQ	E
<b>Pump version</b>							
A	Basic version						
B	Oversize motor						
F	CR pump for high temperatures (air-cooled top assembly)						
H	Horizontal version						
HS	High-pressure pump with high speed MGE motor						
I	Different pressure rating						
J	Pump w/different max. speed						
K	Pump with low NPSH						
M	Magnetic drive						
N	Fitted with sensor						
P	Undersize motor						
R	Horizontal version with bearing bracket						
SF	High pressure pump						
X	Special version						
<b>Pipe connection</b>							
A	Oval flange						
B	NPT thread						
CA	FlexiClamp (CRI(E), CRN(E) 1, 3, 5, 10, 15, 20)						
F	DIN flange						
G	ANSI flange						
J	JIS flange						
N	Changed diameter of ports						
P	PJE coupling						
X	Special version						
<b>Materials</b>							
A	Basic version						
D	Carbon-graphite filled PTFE (bearings)						
G	Wetted parts 1.4401/AISI 316						
GI	All parts stainless steel, wetted parts 1.4401/AISI 316						
I	Wetted parts 1.4301/AISI 304						
II	All parts stainless steel, wetted parts 1.4301/AISI 304						
K	Bronze (bearings)						
S	SiC bearings + PTFE neck rings						
X	Special version						
<b>Code for rubber parts</b>							
E	EPDM						
F	FXM						
K	FFKM						
V	FKM						
<b>Shaft seal</b>							
H	Balanced cartridge seal						
Q	Silicon carbide						
U	Tungsten carbide						
B	Carbon						
E	EPDM						
F	FXM						
K	FFKM						
V	FKM						

# Operating and inlet pressures

CR, CRI, CRN, CRE, CRIE, CRNE

## Maximum operating pressure and temperature range

	Oval flange		PJE, Clamp, UNION, DIN	
	Max. permissible operating pressure	Liquid temperature range	Max. permissible operating pressure	Liquid temperature range
CR, CRI, CRN 1s	16 bar	-20°C to +120°C	25 bar	-20°C to +120°C
CR(E), CRI(E), CRN(E) 1	16 bar	-20°C to +120°C	25 bar	-20°C to +120°C
CR(E), CRI(E), CRN(E) 3	16 bar	-20°C to +120°C	25 bar	-20°C to +120°C
CR(E), CRI(E), CRN(E) 5	16 bar	-20°C to +120°C	25 bar	-20°C to +120°C
CR(E), CRI(E), CRN(E) 10-1 → CR(E), CRI(E), CRN(E) 10-16	16 bar	-20°C to +120°C	16 bar	-20°C to +120°C
CR(E), CRI(E), CRN(E) 10-17 → CR(E), CRI(E), CRN(E) 10-22	-	-	25 bar	-20°C to +120°C
CR(E), CRI(E), CRN(E) 15-1 → CR(E), CRI(E), CRN(E) 15-7	10 bar	-20°C to +120°C	-	-
CR(E), CRI(E), CRN(E) 15-1 → CR(E), CRI(E), CRN(E) 15-10	-	-	16 bar	-20°C to +120°C
CR(E), CRI(E), CRN(E) 15-12 → CR(E), CRI(E), CRN(E) 15-17	-	-	25 bar	-20°C to +120°C
CR(E), CRI(E), CRN(E) 20-1 → CR(E), CRI(E), CRN(E) 20-7	10 bar	-20°C to +120°C	-	-
CR(E), CRI(E), CRN(E) 20-1 → CR(E), CRI(E), CRN(E) 20-10	-	-	16 bar	-20°C to +120°C
CR(E), CRI(E), CRN(E) 20-12 → CR(E), CRI(E), CRN(E) 20-17	-	-	25 bar	-20°C to +120°C
CR(E), CRN(E) 32-1-1 → CR(E), CRN(E) 32-7	-	-	16 bar	-30°C to +120°C
CR(E), CRN(E) 32-8-2 → CR(E), CRN(E) 32-14	-	-	30 bar	-30°C to +120°C
CR(E), CRN(E) 45-1-1 → CR(E), CRN(E) 45-5	-	-	16 bar	-30°C to +120°C
CR(E), CRN(E) 45-6-2 → CR, CRN 45-11	-	-	30 bar	-30°C to +120°C
CR, CRN 45-12-2 → CR, CRN 45-13-2	-	-	33 bar	-30°C to +120°C
CR(E), CRN(E) 64-1-1 → CR(E), CRN(E) 64-5	-	-	16 bar	-30°C to +120°C
CR, CRN 64-6-2 → CR, CRN 64-8-1	-	-	30 bar	-30°C to +120°C
CR(E), CRN(E) 90-1-1 → CR(E), CRN(E) 90-4	-	-	16 bar	-30°C to +120°C
CR, CRN 90-5-2 → CR, CRN 90-6	-	-	30 bar	-30°C to +120°C

## Operating range of the shaft seal

The operating range of the shaft seal depends on operating pressure, pump type, type of shaft seal and liquid temperature. The following curves apply to clean water and water with anti-freeze liquids. For selecting the right shaft seal, see 'List of pumped liquids' page 68.

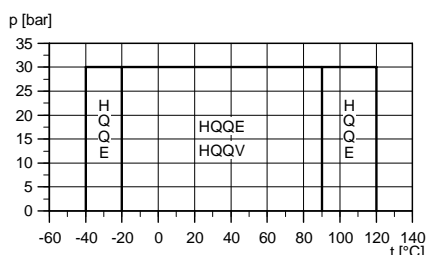

Fig. 14 Operating range of standard shaft seals

Shaft seal	Description	Max. temp. range [°C]
HQQE	O-ring (cartridge) (balanced seal), SiC/SiC, EPDM	-40°C to +120°C
HQQV	O-ring (cartridge) (balanced seal), SiC/SiC, FKM	-20°C to +90°C

In case of extreme temperatures, i.e.

- low temperatures down to -40°C or
  - high temperatures up to +180°C,
- see "List of variants - on request" on page 79.

## Maximum inlet pressure

The following table shows the maximum permissible inlet pressure. However, the current inlet pressure + the pressure against a closed valve **must** always be lower than the maximum permissible operating pressure.

If the maximum permissible operating pressure is exceeded, the conical bearing in the motor may be damaged and the life of the shaft seal reduced.

CR, CRI, CRN 1s		
1s-2	› 1s-36	10 bar
CR(E), CRI(E), CRN(E) 1		
1-2	› 1-36	10 bar
CR(E), CRI(E), CRN(E) 3		
3-2	› 3-29	10 bar
3-31	› 3-36	15 bar
CR(E), CRI(E), CRN(E) 5		
5-2	› 5-16	10 bar
5-18	› 5-36	15 bar
CR(E), CRI(E), CRN(E) 10		
10-1	› 10-6	8 bar
10-7	› 10-22	10 bar
CR(E), CRI(E), CRN(E) 15		
15-1	› 15-3	8 bar
15-4	› 15-17	10 bar
CR(E), CRI(E), CRN(E) 20		
20-1	› 20-3	8 bar
20-4	› 20-17	10 bar
CR(E), CRN(E) 32		
32-1-1	› 32-4	4 bar
32-5-2	› 32-10	10 bar
32-11	› 32-14	15 bar
CR(E), CRN(E) 45		
45-1-1	› 45-2	4 bar
45-3-2	› 45-5	10 bar
45-6-2	› 45-13-2	15 bar
CR(E), CRN(E) 64		
64-1-1	› 64-2-2	4 bar
64-2-1	› 64-4-2	10 bar
64-4-1	› 64-8-1	15 bar
CR(E), CRN(E) 90		
90-1-1	› 90-1	4 bar
90-2-2	› 90-3-2	10 bar
90-3	› 90-6	15 bar

## Examples of operating and inlet pressures

The values for operating and inlet pressures shown in the table must not be considered individually but must always be compared, see the following examples:

### Example 1:

The following pump type has been selected:  
CR 5-16 A-A-A

Max. operating pressure: **16 bar**

Max. inlet pressure: **10 bar**

Discharge pressure against a closed valve: **10.6 bar**, see page 41.

This pump is **not** allowed to start at an inlet pressure of 10 bar, but at an inlet pressure of  $16.0 - 10.6 = 5.4$  bar.

### Example 2:

The following pump type has been selected:  
CR 10-2 A-A-A

Max. operating pressure: **16 bar**

Max. inlet pressure: **8.0 bar**

Discharge pressure against a closed valve: **2.0 bar**, see page 73.

This pump is allowed to start at an inlet pressure of 8.0 bar, as the discharge pressure against a closed valve is only 2.0 bar, which results in an operating pressure of  $8.0 + 2.0 = 10.0$  bar. On the contrary, the max. operating pressure of this pump is limited to 16.0 bar, as a higher operating pressure will require an inlet pressure of more than 8.0 bar.

In case the inlet or operating pressure exceeds the pressure permitted, see "Lists of variants - on request" page 79.



## Selection of pumps

Selection of pumps should be based on:

- The duty point of the pump (see section 1)
- Dimensional data such as pressure loss as a result of height differences, friction loss in the pipework, pump efficiency etc. (see section 2)
- Pump materials (see section 3)
- Pump connections (see section 4)
- Shaft seal (see section 5).

### 1. Duty point of the pump

From a duty point it is possible to select a pump on the basis of the curve charts shown in "Performance curves" from page 29.

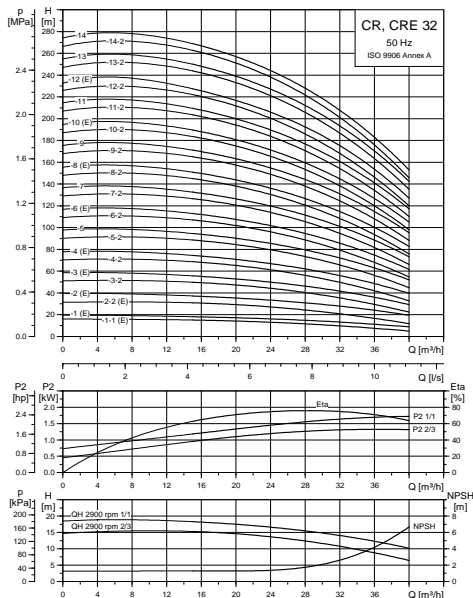

Fig. 15 Example of a curve chart

### 2. Dimensional data

When sizing a pump the following must be taken into account:

- Required flow and pressure at the draw-off point.
- Pressure loss as a result of height differences ( $H_{geo}$ ).
- Friction loss in the pipework ( $H_f$ ).  
It may be necessary to account for pressure loss in connection with long pipes, bends or valves, etc.
- Best efficiency at the estimated duty point.
- NPSH value.  
For calculation of the NPSH value, see "Minimum inlet pressure - NPSH", page 20.

### Pump efficiency

Before determining the best efficiency point, the operation pattern of the pump needs to be identified.

Is the pump expected to operate at the **same** duty point, then select a CR pump which is operating at a duty point corresponding with the best efficiency of the pump.

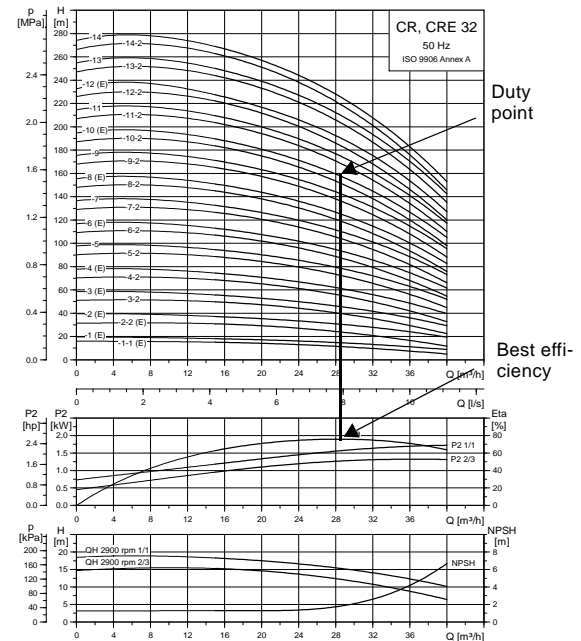

Fig. 16 Example of a CR pump's duty point

As the pump is sized on the basis of the highest possible flow, it is important always to have the duty point to the right on the efficiency curve (eta) in order to keep efficiency high when the flow drops.

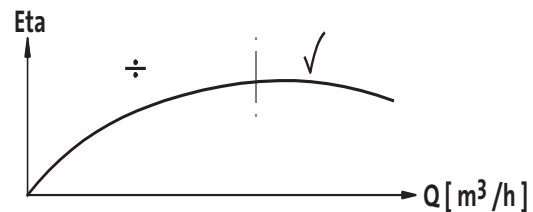

Fig. 17 Best efficiency

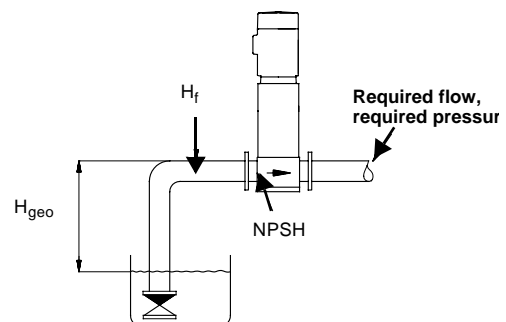

Fig. 18 Dimensional data

Normally, E-pumps are used in applications characterized by a **variable** flow. Consequently, it is not possible to select a pump that is constantly operating at optimum efficiency.

In order to achieve optimum operating economy, the pump should be selected on the basis of the following criteria:

- The max. duty point required should be as close as possible to the QH curve of the pump.
- The required duty point should be positioned so that  $P_2$  is close to the max. point of the QH curve.

Between the min. and max. performance curve E-pumps have an infinite number of performance curves each representing a specific speed. Therefore it may not be possible to select a duty point close to the 100% curve.

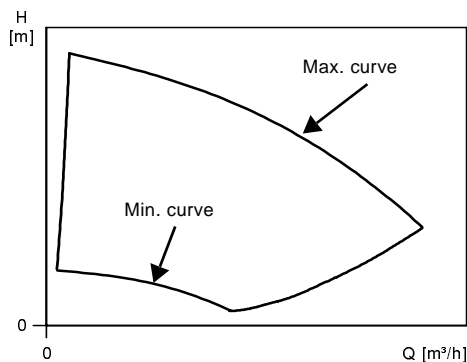

Fig. 19 Min. and max. performance curves

In situations where it is not possible to select a duty point close to the 100% curve the below affinity equations can be used. The head (H), the flow (Q) and the input power (P) are all the appropriate variables for the motor speed (n).

**Note:**

The approximated formulas apply on condition that the system characteristic remains unchanged for  $n_n$  and  $n_x$  and that it is based on the formula  $H = k \times Q^2$ , where k is a constant.

The power equation implies that the pump efficiency is unchanged at the two speeds. In practice this is **not** quite correct.

Finally, it is worth noting that the efficiencies of the frequency converter and the motor **must** be taken into account if a precise calculation of the power saving resulting from a reduction of the pump speed is wanted.

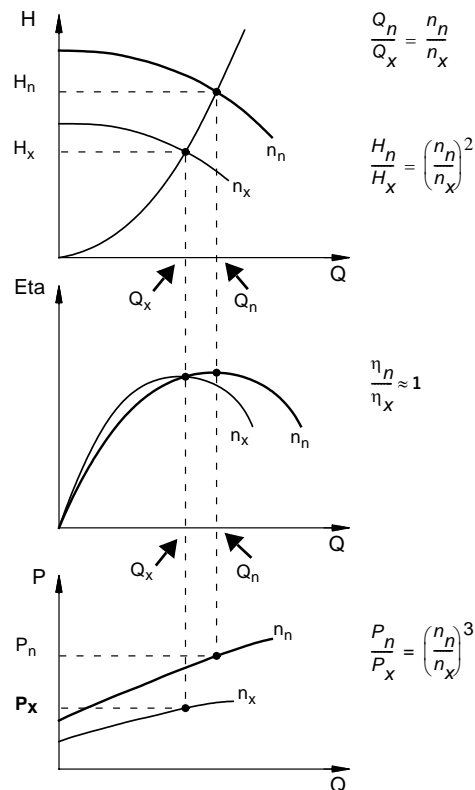

Fig. 20 Affinity equations

**Legend**

- $H_n$  Rated head in metres
- $H_x$  Current head in metres
- $Q_n$  Rated flow in  $m^3/h$
- $Q_x$  Current flow in  $m^3/h$
- $n_n$  Rated motor speed in  $min^{-1}$  ( $n_n = 2900 min^{-1}$ )
- $n_x$  Current motor speed in  $min^{-1}$
- $\eta_n$  Rated efficiency in %
- $\eta_x$  Current efficiency in %

**WinCAPS and WebCAPS**

WinCAPS and WebCAPS are both selection programmes offered by Grundfos.

The two programmes make it possible to calculate an E-pump's specific duty point and energy consumption.

By entering the dimensional data of the pump, WinCAPS and WebCAPS can calculate the exact duty point and energy consumption. For further information see page 80 and page 81.

TM01 4916 4803

TM00 8720 3496

### 3. Pump material

The material variant (CR(E), CRI(E), CRN(E)) should be selected based of the liquid to be pumped. The product range covers the following three basic types.

- The CR(E), CRI(E) pump types are suitable for clean, non-aggressive liquids such as potable water, oils, etc.
- The CRN(E) pump type is suitable for industrial liquids and acids, see" "List of pumped liquids" on page 68 or contact Grundfos.

For saline or chloride-containing liquids such as sea water, CRT(E) pumps of titanium are available.

### 4. Pump connections

Selection of pump connection depends on the rated pressure and pipework. To meet any requirement the CR(E), CRI(E) and CRN(E) pumps offer a wide range of flexible connections such as:

- Oval flange (BSP)
- DIN flange
- PJE coupling
- Clamp coupling
- Union (+GF+)
- Other connections on request.

### 5. Shaft seal

As standard, the CR(E) range is fitted with a Grundfos shaft seal (cartridge type) suitable for the most common applications.

The following key parameters **must** be taken into account, when selecting the shaft seal:

- Type of pumped liquid
- liquid temperature and
- maximum pressure.

Grundfos offers a wide range of shaft seal variants to meet specific demands see "List of pumped liquids" on page 68.

### Inlet pressure and operating pressure

The limit values stated on page 15 and page 16 must **not** be exceeded as regards ...

- maximum inlet pressure and
- maximum operating pressure.

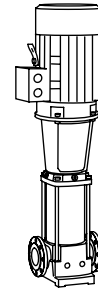

Fig. 21 CR pump

TM01 2100 1198

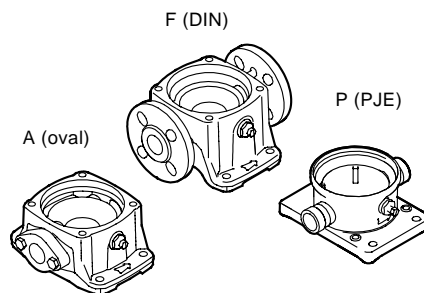

Fig. 22 Pump connections

TM02 1201 0601

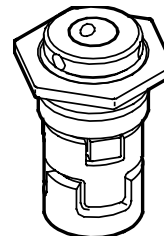

Fig. 23 Shaft seal (cartridge type)

TM02 0538 4800

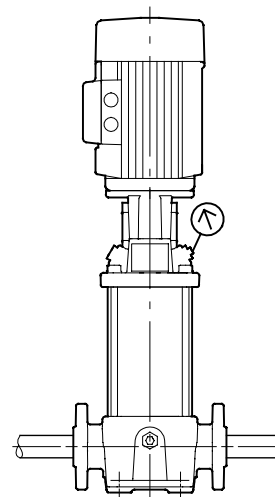

Fig. 24 Inlet and operating pressure

TM02 1204 060

## Minimum inlet pressure - NPSH

Calculation of the inlet pressure "H" is recommended when

- the liquid temperature is high,
- the flow is significantly higher than the rated flow,
- water is drawn from depths,
- water is drawn through long pipes,
- inlet conditions are poor.

To avoid cavitation, make sure that there is a minimum pressure on the suction side of the pump. The maximum suction lift "H" in metres head can be calculated as follows:

$$H = p_b \times 10.2 - \text{NPSH} - H_f - H_v - H_s$$

$p_b$  = Barometric pressure in bar.

(Barometric pressure can be set to 1 bar).

In closed systems,  $p_b$  indicates the system pressure in bar.

NPSH= Net Positive Suction Head in metres head.  
(To be read from the NPSH curve at the highest flow the pump will be delivering).

$H_f$  = Friction loss in suction pipe in metres head.  
(At the highest flow the pump will be delivering.)

$H_v$  = Vapour pressure in metres head.  
(To be read from the vapour pressure scale.  
"H<sub>v</sub>" depends on the liquid temperature "T<sub>m</sub>").

$H_s$  = Safety margin = minimum 0.5 metres head.

If the "H" calculated is positive, the pump can operate at a suction lift of maximum "H" metres head.

If the "H" calculated is negative, an inlet pressure of minimum "H" metres head is required.

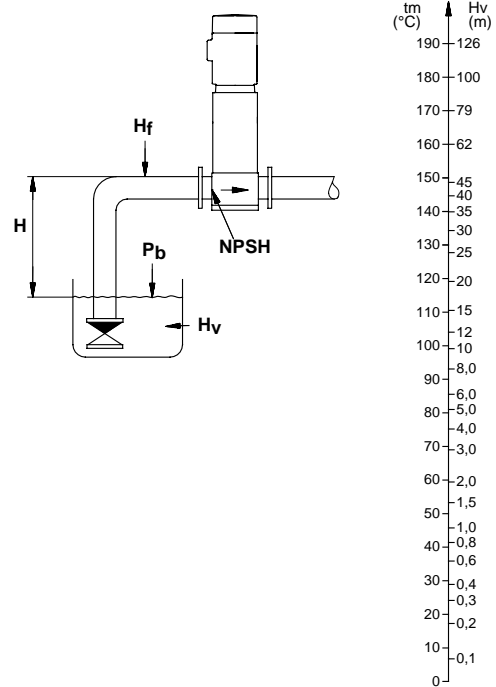

Fig. 25 Minimum inlet pressure - NPSH

**Note:** In order to avoid cavitation **never** select a pump with a duty point too far to the right on the NPSH curve.

Always check the NPSH value of the pump at the highest possible flow.

TM02 7439 3403

## How to read the curve charts

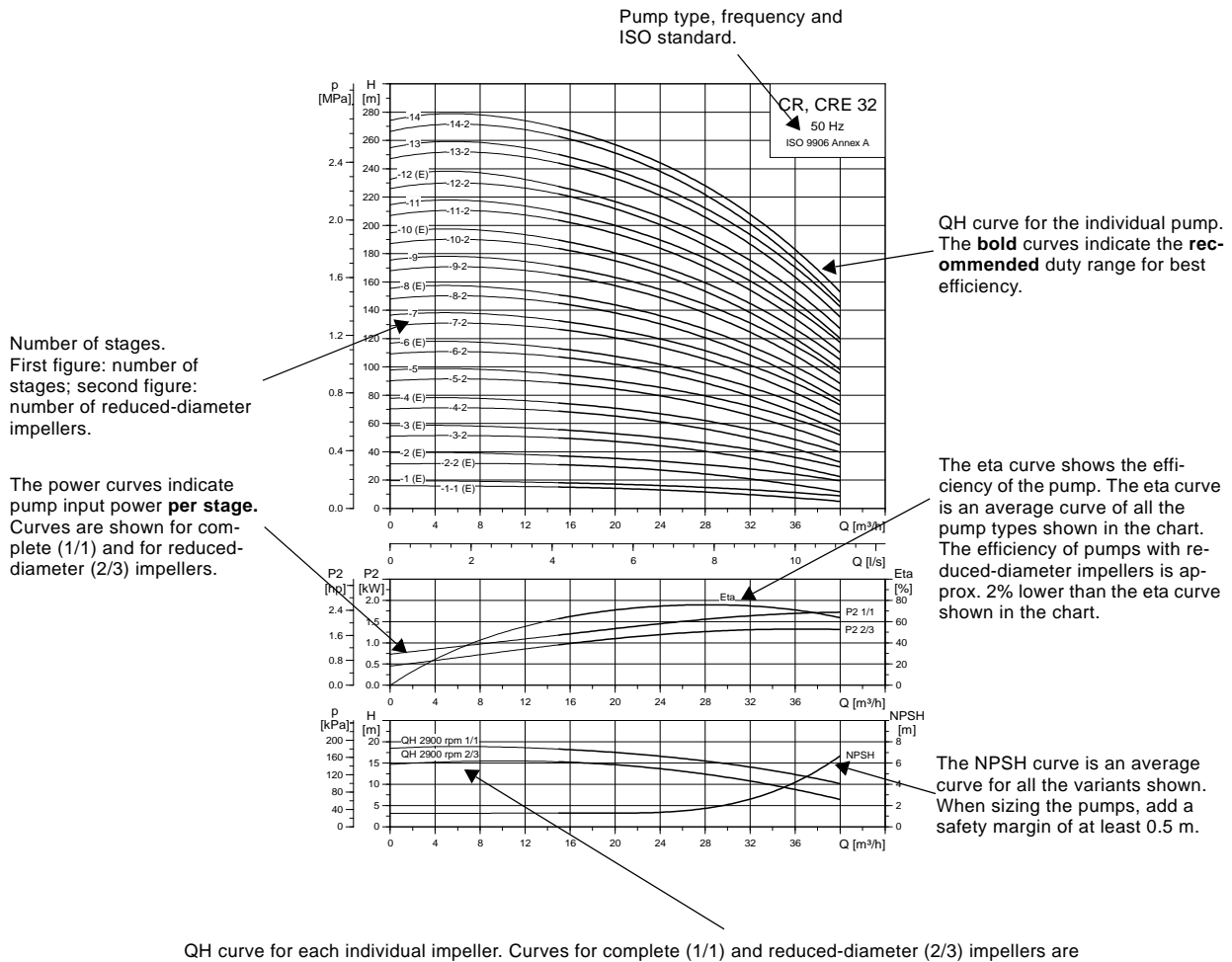

Fig. 26 How to read the curve charts

## Guidelines to performance curves

The guidelines below apply to the curves shown on the following pages:

- Tolerances to ISO 9906, Annex A, if indicated.
- The motors used for the measurements are standard Grundfos motors (MG or MGE).
- Measurements have been made with airless water at a temperature of 20°C.
- The curves apply to a kinematic viscosity of  $\nu = 1 \text{ mm}^2/\text{s}$  (1 cSt).
- Due to the risk of overheating, the pumps should not be used at a flow below the minimum flow rate.
- The QH curves apply to a rated motor speed of  $2900 \text{ min}^{-1}$ . All curves are based on current motor speeds.

The curve below shows the minimum flow rate as a percentage of the nominal flow rate in relation to the liquid temperature. The dotted line shows a CR pump fitted with an air-cooled top assembly.

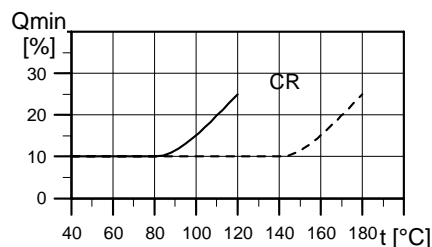

Fig. 27 Minimum flow rate

TM02 7302 3103

TM01 2816 0303

# Performance curves

## Technical data

CR 1s

### CR 1s

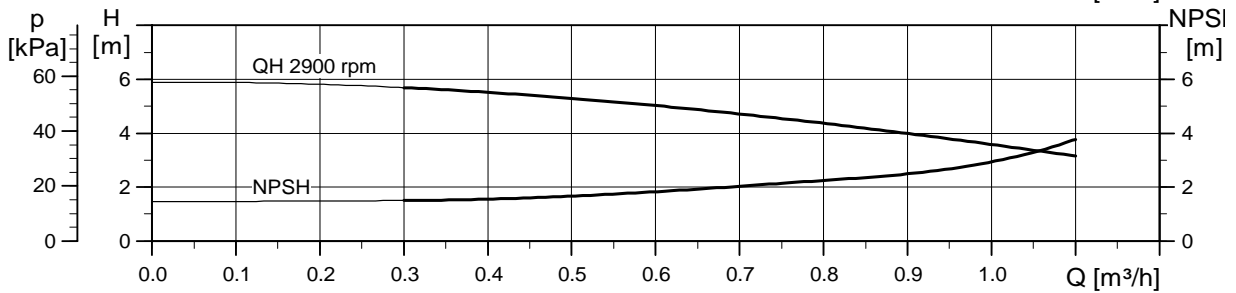
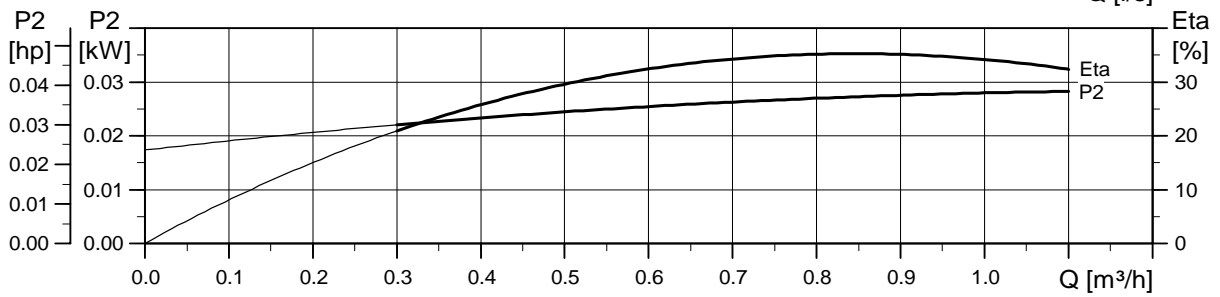
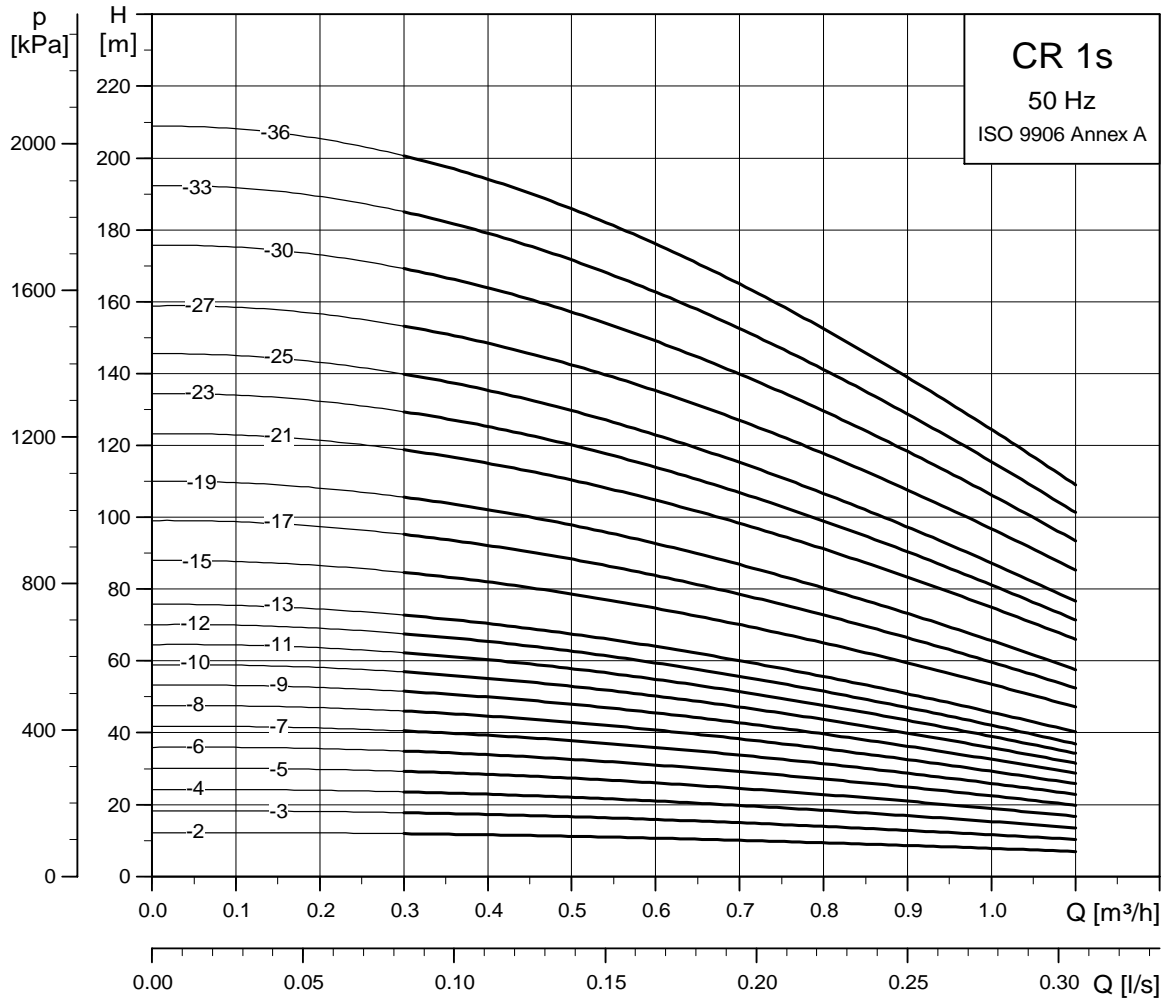

TM02 7424 3605



## CRI, CRN 1s

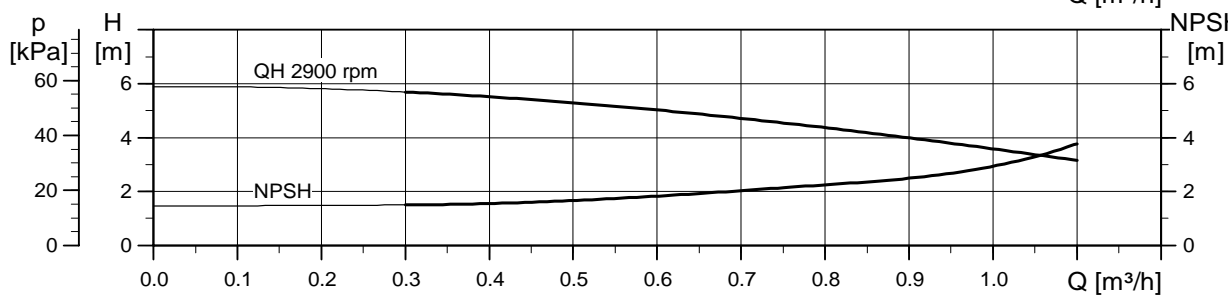
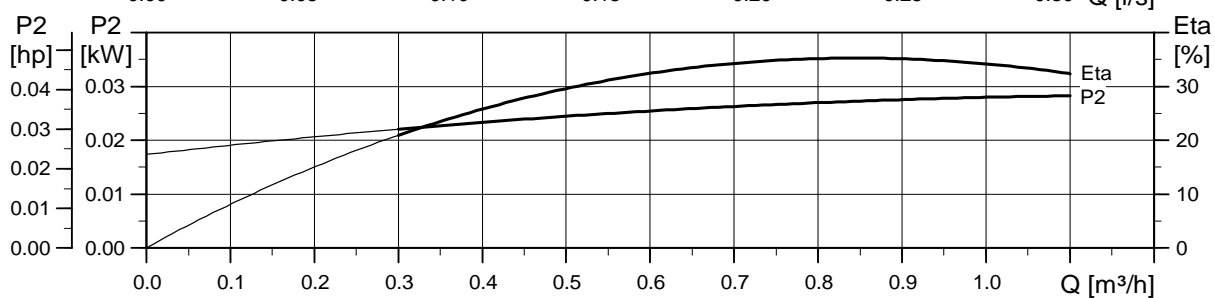
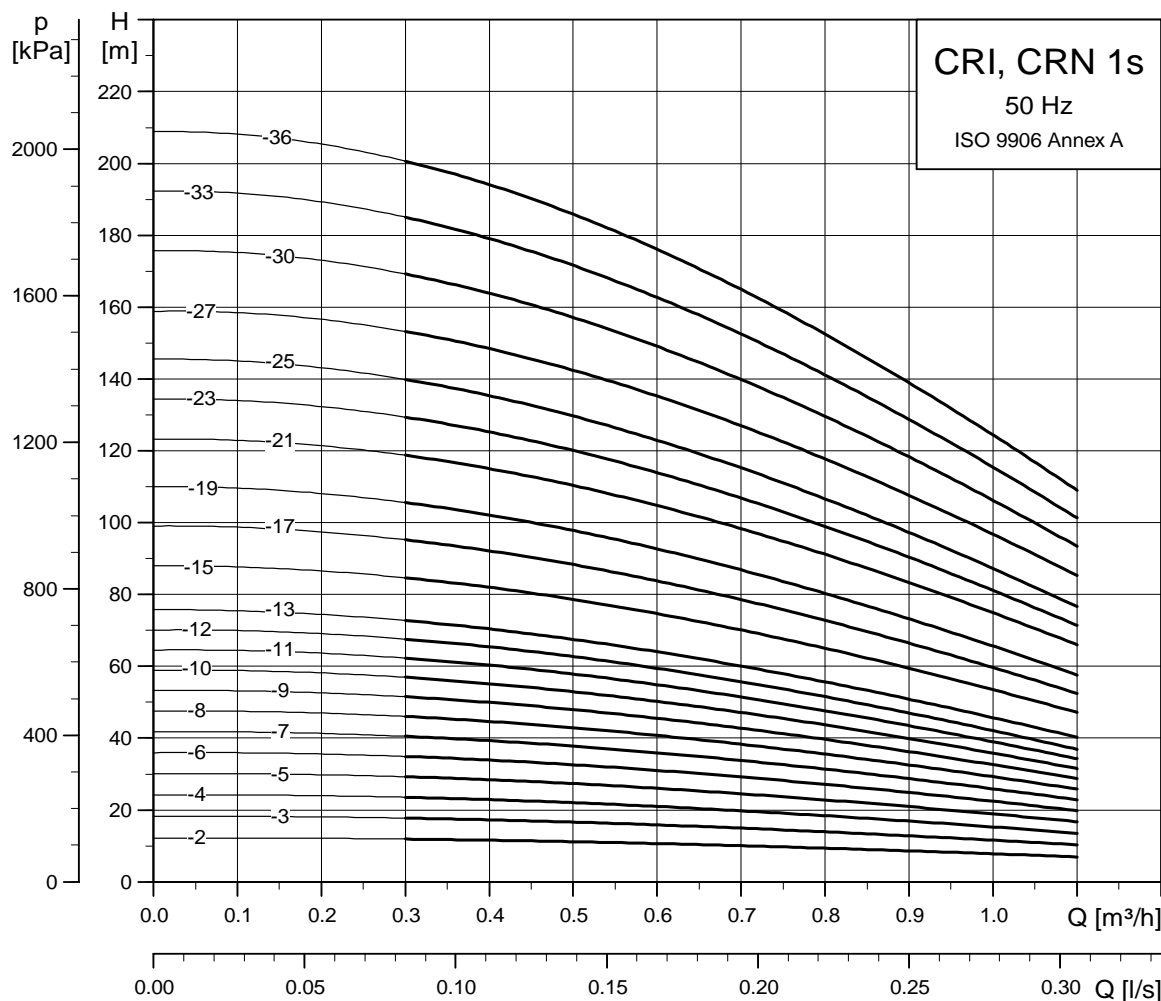

TM02 7425 3605



## Dimensional sketch

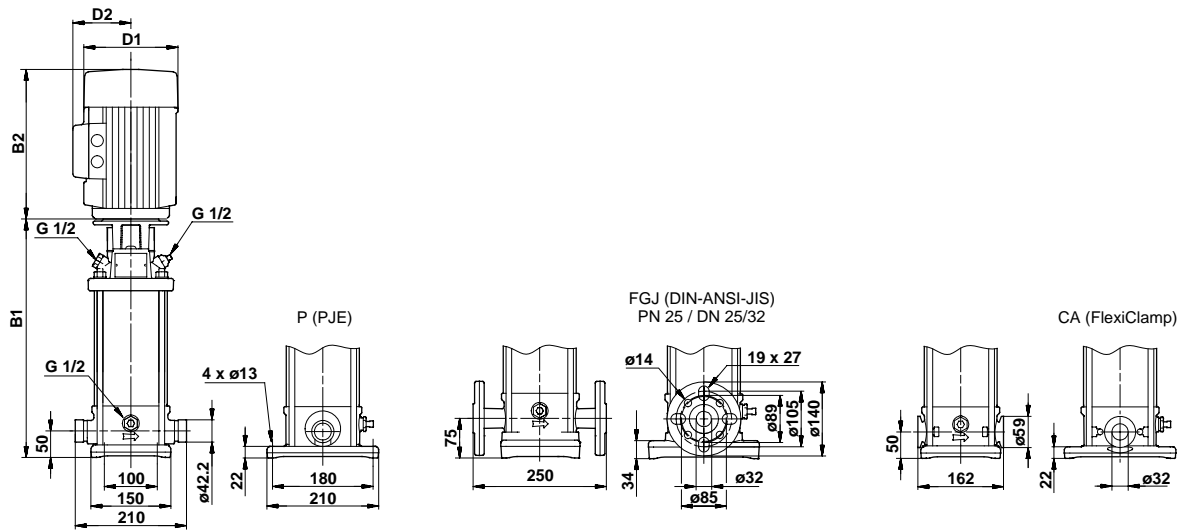

TM03 1722 2805

## Dimensions and weights

Pump type	Motor P <sub>2</sub> [kW]	Dimension [mm]						Net weight [kg]		
		PJE/CA		DIN flange		B2	D1	D2	PJE/CA	DIN flange
		B1	B1+B2	B1	B1+B2					
CRI/CRN 1s-2	0.37	257	448	282	473	191	141	109	16	20
CRI/CRN 1s-3	0.37	257	448	282	473	191	141	109	16	21
CRI/CRN 1s-4	0.37	275	466	300	491	191	141	109	17	21
CRI/CRN 1s-5	0.37	293	484	318	509	191	141	109	17	21
CRI/CRN 1s-6	0.37	311	502	336	527	191	141	109	18	22
CRI/CRN 1s-7	0.37	329	520	354	545	191	141	109	18	22
CRI/CRN 1s-8	0.37	347	538	372	563	191	141	109	18	23
CRI/CRN 1s-9	0.37	365	556	390	581	191	141	109	19	23
CRI/CRN 1s-10	0.37	383	574	408	599	191	141	109	19	23
CRI/CRN 1s-11	0.37	401	592	426	617	191	141	109	19	24
CRI/CRN 1s-12	0.37	419	610	444	635	191	141	109	20	24
CRI/CRN 1s-13	0.37	437	628	462	653	191	141	109	20	25
CRI/CRN 1s-15	0.55	473	664	498	689	191	141	109	22	26
CRI/CRN 1s-17	0.55	509	700	534	725	191	141	109	23	27
CRI/CRN 1s-19	0.55	545	736	570	761	191	141	109	23	28
CRI/CRN 1s-21	0.75	587	818	612	843	231	141	109	26	31
CRI/CRN 1s-23	0.75	623	854	648	879	231	141	109	27	31
CRI/CRN 1s-25	0.75	659	890	684	915	231	141	109	28	32
CRI/CRN 1s-27	1.1	695	926	720	951	231	141	109	31	35
CRI/CRN 1s-30	1.1	749	980	774	1005	231	141	109	32	36
CRI/CRN 1s-33	1.1	803	1034	828	1059	231	141	109	33	37
CRI/CRN 1s-36	1.1	857	1088	882	1113	231	141	109	34	39

## CR, CRE 1

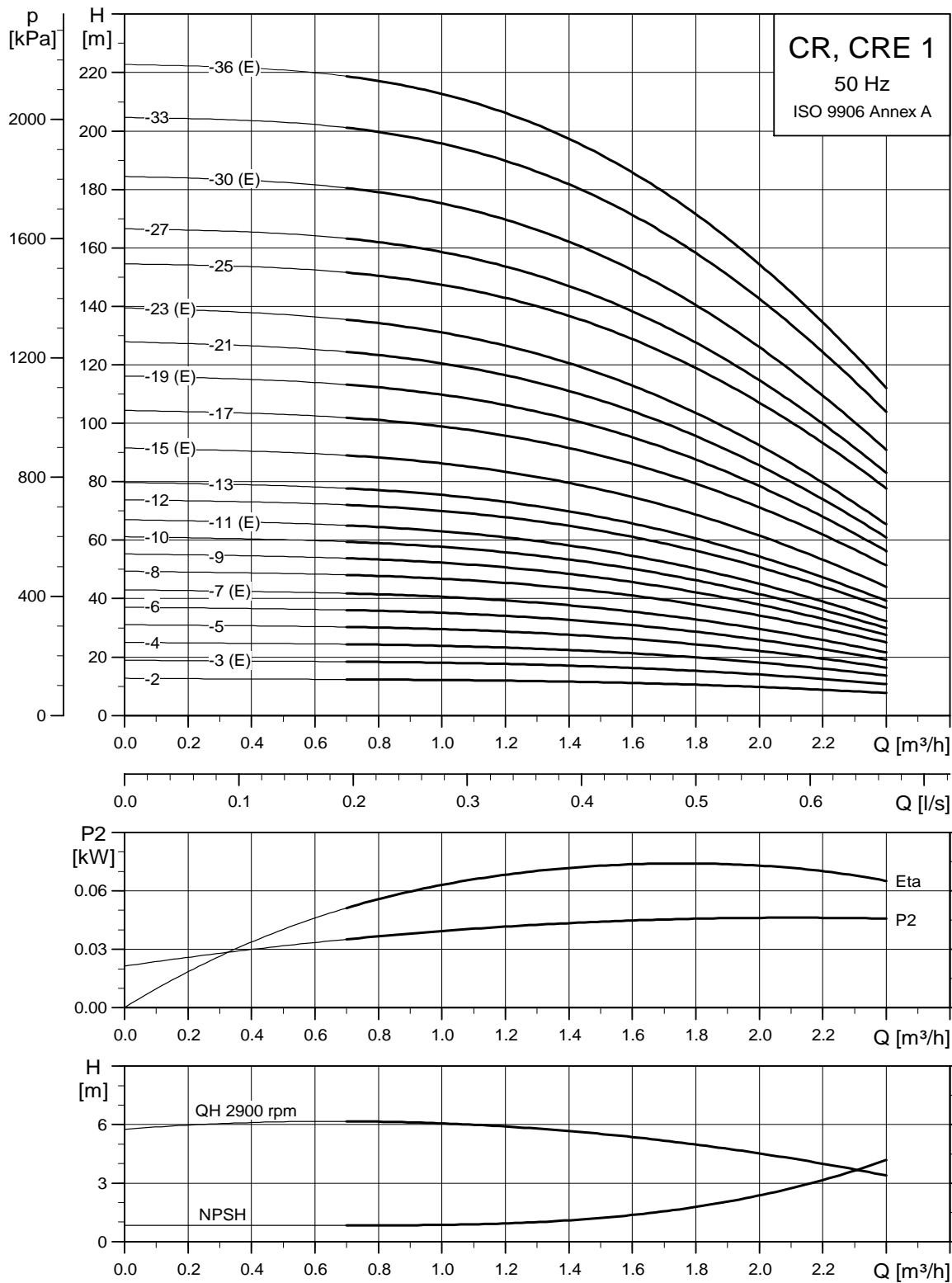

TM02 7290 3605

## Dimensional sketch

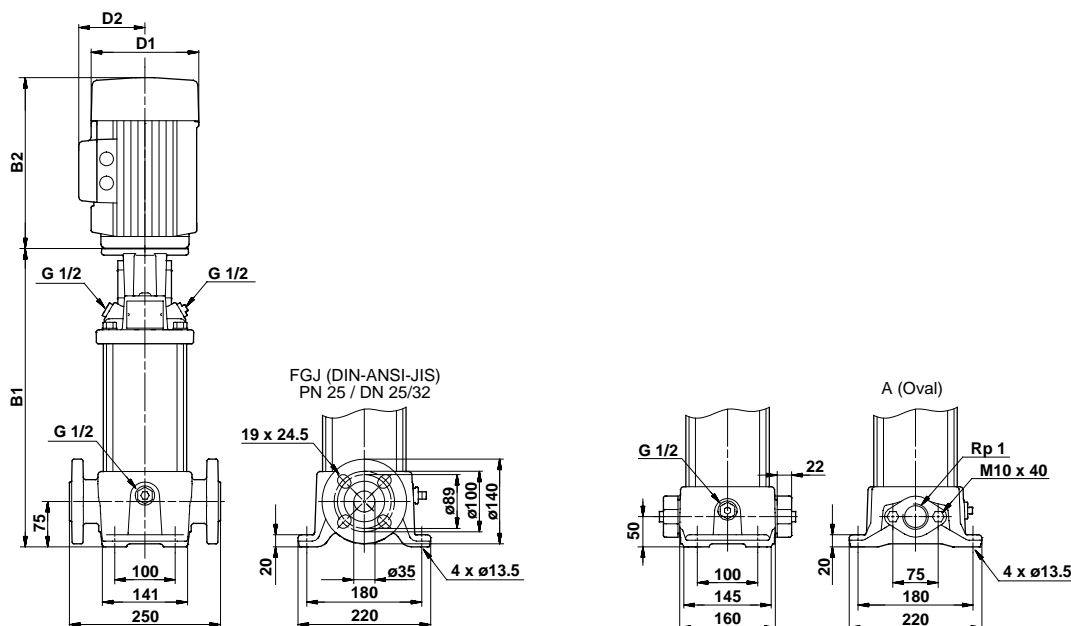

TM03 1721 2805

## Dimensions and weights

Pump type	Motor P <sub>2</sub> [kW]	CR								CRE							
		Dimension [mm]				Net weight [kg]				Dimension [mm]				Net weight [kg]			
		Oval flange		DIN flange		D1	D2	Oval flange	DIN flange	Oval flange		DIN flange		D1	D2	Oval flange	DIN flange
		B1	B1+B2	B1	B1+B2					B1	B1+B2	B1	B1+B2				
CR 1-2	0.37	254	445	279	470	141	109	18	23	-	-	-	-	-	-	-	
CR(E) 1-3	0.37	254	445	279	470	141	109	18	23	254	445	279	470	141	140	19.8	23.9
CR 1-4	0.37	272	463	297	488	141	109	19	23	-	-	-	-	-	-	-	
CR 1-5	0.37	290	481	315	506	141	109	19	24	-	-	-	-	-	-	-	
CR 1-6	0.37	308	499	333	524	141	109	20	24	-	-	-	-	-	-	-	
CR(E) 1-7	0.37	326	517	351	542	141	109	20	25	326	517	351	542	141	140	21.2	25.3
CR 1-8	0.55	344	535	369	560	141	109	21	26	-	-	-	-	-	-	-	
CR 1-9	0.55	362	553	387	578	141	109	21	26	-	-	-	-	-	-	-	
CR 1-10	0.55	380	571	405	596	141	109	22	26	-	-	-	-	-	-	-	
CR(E) 1-11	0.55	398	589	423	614	141	109	22	27	398	589	423	614	141	140	24.0	28.1
CR 1-12	0.75	422	653	447	678	141	109	24	29	-	-	-	-	-	-	-	
CR 1-13	0.75	440	671	465	696	141	109	25	29	-	-	-	-	-	-	-	
CR(E) 1-15	0.75	476	707	501	732	141	109	26	30	476	707	501	732	178	167	28.7	32.7
CR 1-17	1.1	512	743	537	768	141	109	29	33	-	-	-	-	-	-	-	
CR(E) 1-19	1.1	548	779	573	804	141	109	29	34	548	779	573	804	178	167	30.8	34.9
CR 1-21	1.1	584	815	609	840	141	109	30	35	-	-	-	-	-	-	-	
CR(E) 1-23	1.1	620	851	645	876	141	109	31	36	620	851	645	876	178	167	32.4	36.5
CR 1-25	1.5	-	-	697	978	178	110	-	44	-	-	-	-	-	-	-	
CR 1-27	1.5	-	-	733	1014	178	110	-	44	-	-	-	-	-	-	-	
CR(E) 1-30	1.5	-	-	787	1068	178	110	-	46	-	-	787	1068	178	167	-	51.2
CR 1-33	2.2	-	-	841	1162	178	110	-	47	-	-	-	-	-	-	-	
CR(E) 1-36	2.2	-	-	895	1216	178	110	-	49	-	-	895	1216	178	167	-	58.3

## CRI, CRN, CRIE, CRNE 1

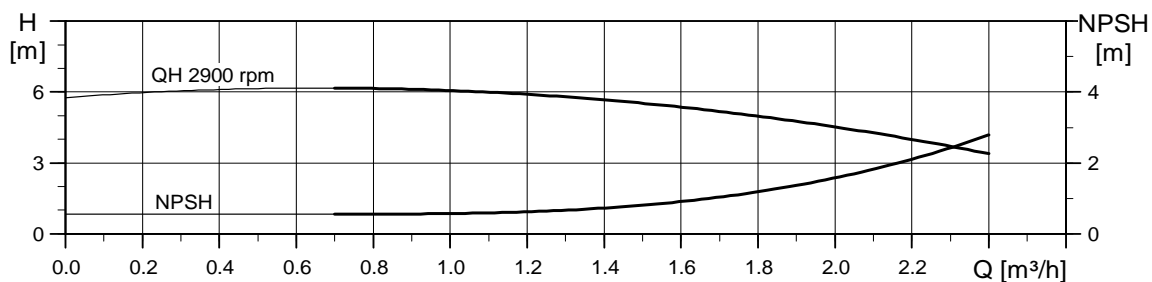
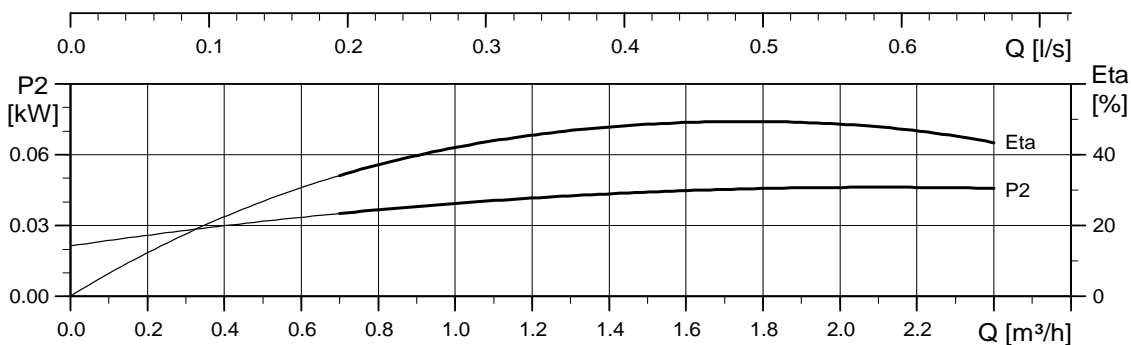
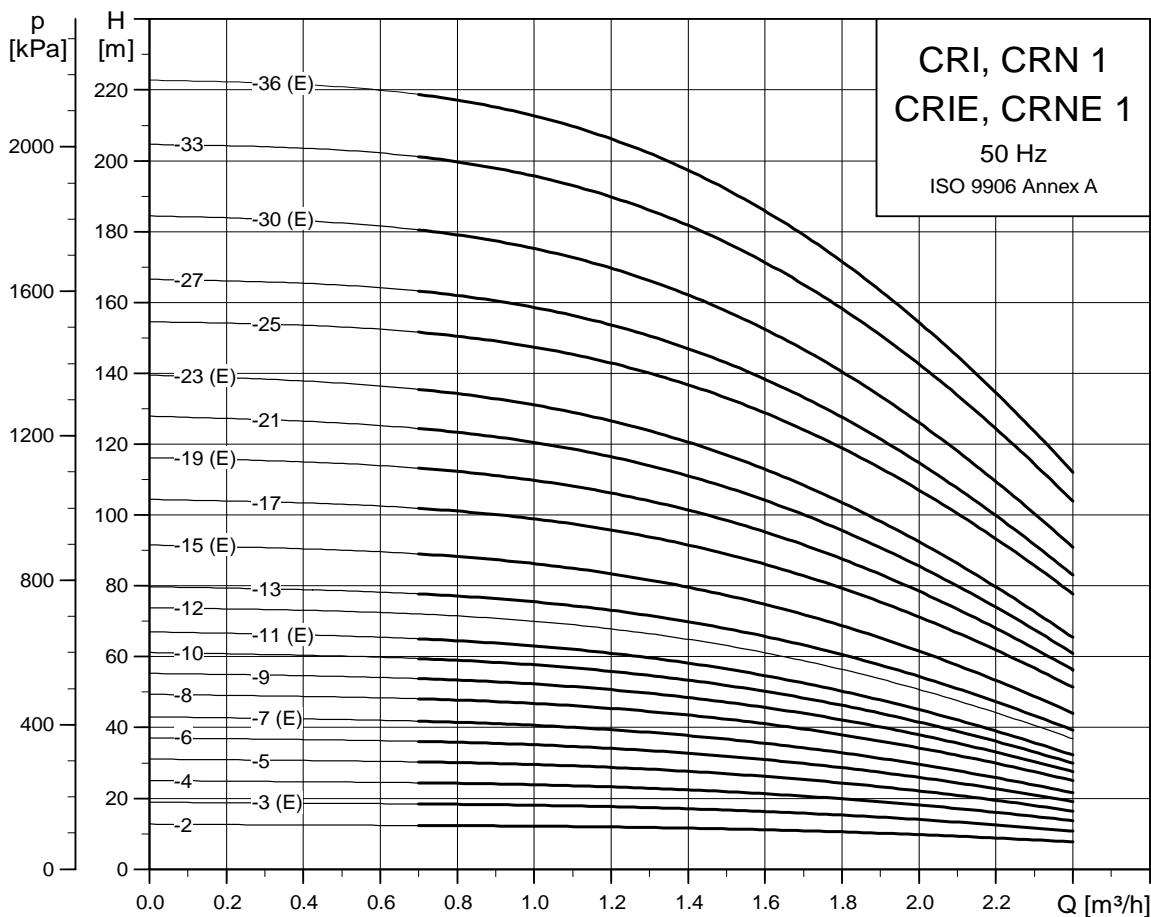

TM02 7291 3605

## Dimensional sketch

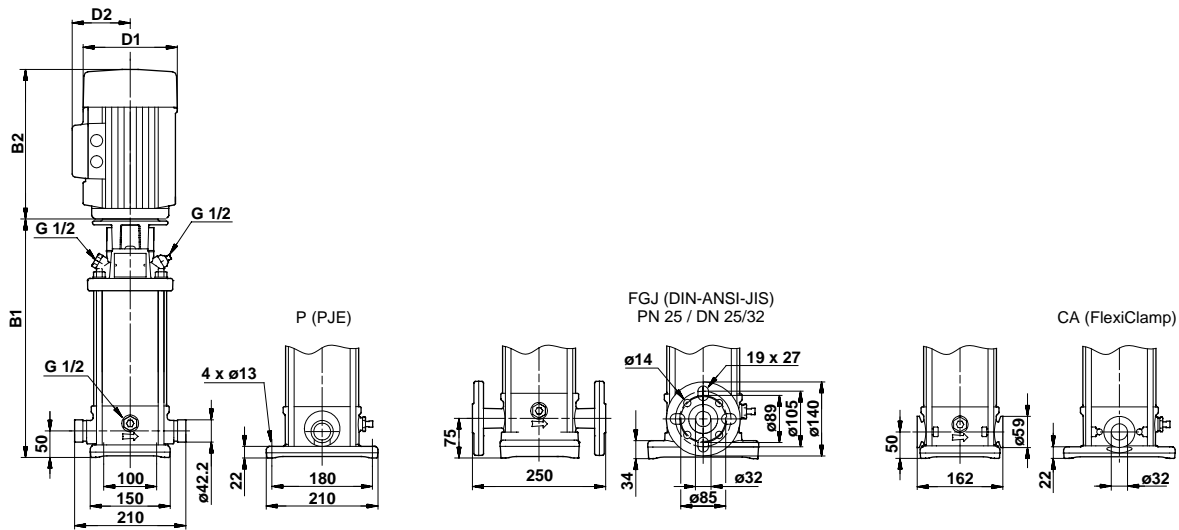

TM03 1722 2805

## Dimensions and weights

Pump type	Motor P <sub>2</sub> [kW]	CRI/CRN								CRIE/CRNE							
		Dimension [mm]				Net weight [kg]				Dimension [mm]				Net weight [kg]			
		PJE/CA		DIN flange		D1	D2	PJE/CA	DIN flange	PJE/CA		DIN flange		D1	D2	PJE/CA	DIN flange
		B1	B1+B2	B1	B1+B2					B1	B1+B2	B1	B1+B2				
CRI/CRN 1-2	0.37	257	448	282	473	141	109	16	20	-	-	-	-	-	-	-	-
CRI(E)/CRN(E) 1-3	0.37	257	448	282	473	141	109	16	21	257	448	282	473	141	140	17.0	20.6
CRI/CRN 1-4	0.37	275	466	300	491	141	109	17	21	-	-	-	-	-	-	-	-
CRI/CRN 1-5	0.37	293	484	318	509	141	109	17	21	-	-	-	-	-	-	-	-
CRI/CRN 1-6	0.37	311	502	336	527	141	109	18	22	-	-	-	-	-	-	-	-
CRI(E)/CRN(E) 1-7	0.37	329	520	354	545	141	109	18	22	329	520	354	545	141	140	18.4	22.0
CRI/CRN 1-8	0.55	347	538	372	563	141	109	19	23	-	-	-	-	-	-	-	-
CRI/CRN 1-9	0.55	365	556	390	581	141	109	20	24	-	-	-	-	-	-	-	-
CRI/CRN 1-10	0.55	383	574	408	599	141	109	20	24	-	-	-	-	-	-	-	-
CRI(E)/CRN(E) 1-11	0.55	401	592	426	617	141	109	20	24	401	592	426	617	141	140	21.2	24.8
CRI/CRN 1-12	0.75	425	656	450	681	141	109	23	27	-	-	-	-	-	-	-	-
CRI/CRN 1-13	0.75	443	674	468	699	141	109	23	28	-	-	-	-	-	-	-	-
CRI(E)/CRN(E) 1-15	0.75	479	710	504	735	141	109	24	28	479	710	504	735	178	167	25.9	29.5
CRI/CRN 1-17	1.1	515	746	540	771	141	109	27	31	-	-	-	-	-	-	-	-
CRI(E)/CRN(E) 1-19	1.1	551	782	576	807	141	109	28	32	551	782	576	807	178	167	28.0	31.6
CRI/CRN 1-21	1.1	587	818	612	843	141	109	29	33	-	-	-	-	-	-	-	-
CRI(E)/CRN(E) 1-23	1.1	623	854	648	879	141	109	30	34	623	854	648	879	178	167	29.6	33.2
CRI/CRN 1-25	1.5	675	956	700	981	178	110	37	41	-	-	-	-	-	-	-	-
CRI/CRN 1-27	1.5	711	992	736	1017	178	110	38	42	-	-	-	-	-	-	-	-
CRI(E)/CRN(E) 1-30	1.5	765	1046	790	1071	178	110	39	43	765	1046	790	1071	178	167	44.3	47.9
CRI/CRN 1-33	2.2	819	1140	844	1165	178	110	41	45	-	-	-	-	-	-	-	-
CRI(E)/CRN(E) 1-36	2.2	873	1194	898	1219	178	110	42	46	873	1194	898	1219	178	167	51.4	55.0

## CR, CRE 3

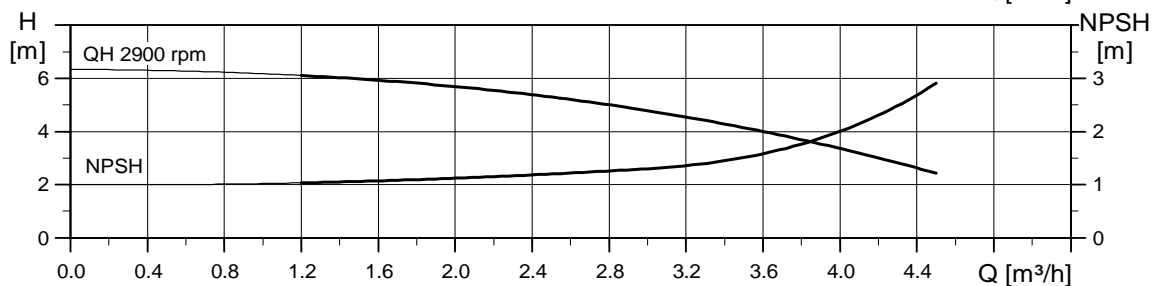
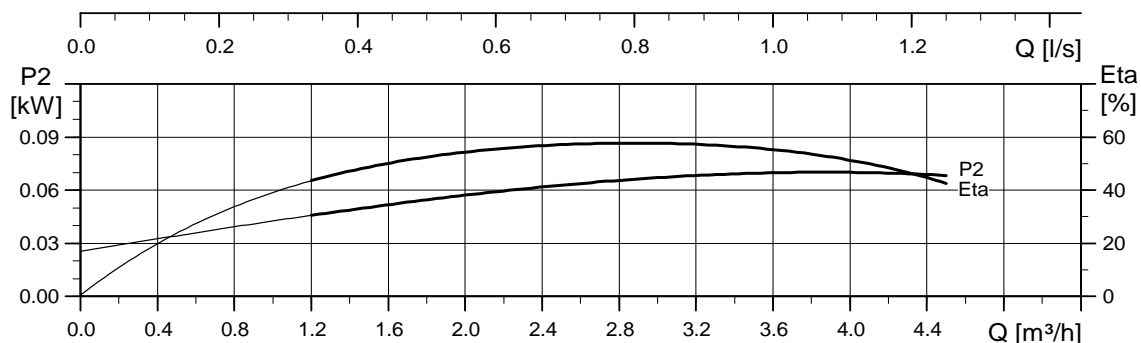
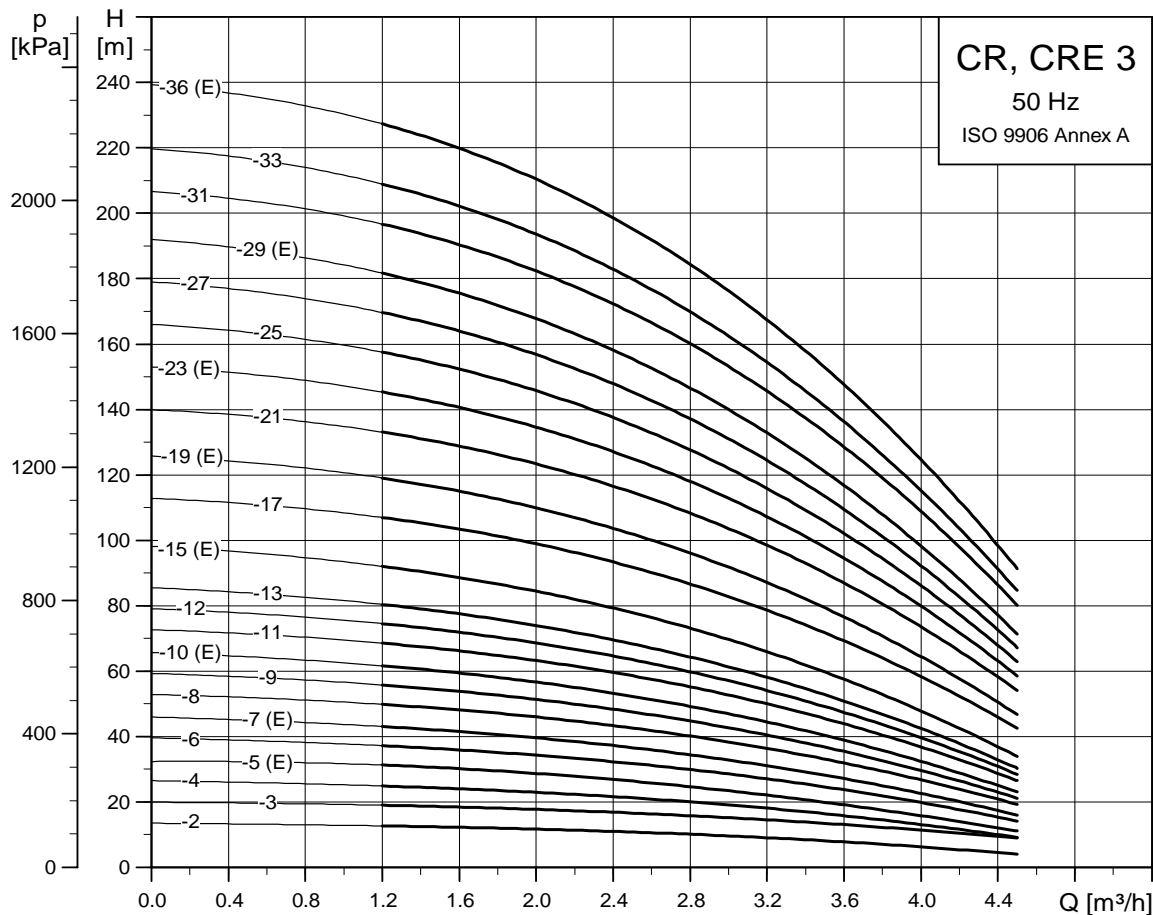

TM02 7292 3605



## CRI, CRN, CRIE, CRNE 3

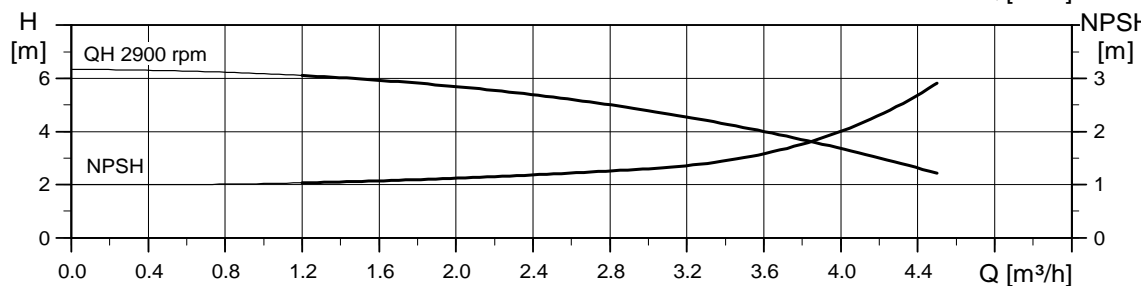
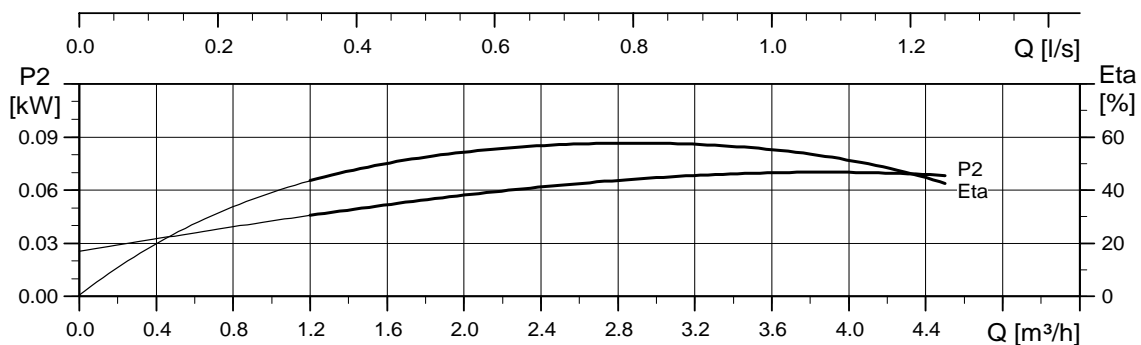
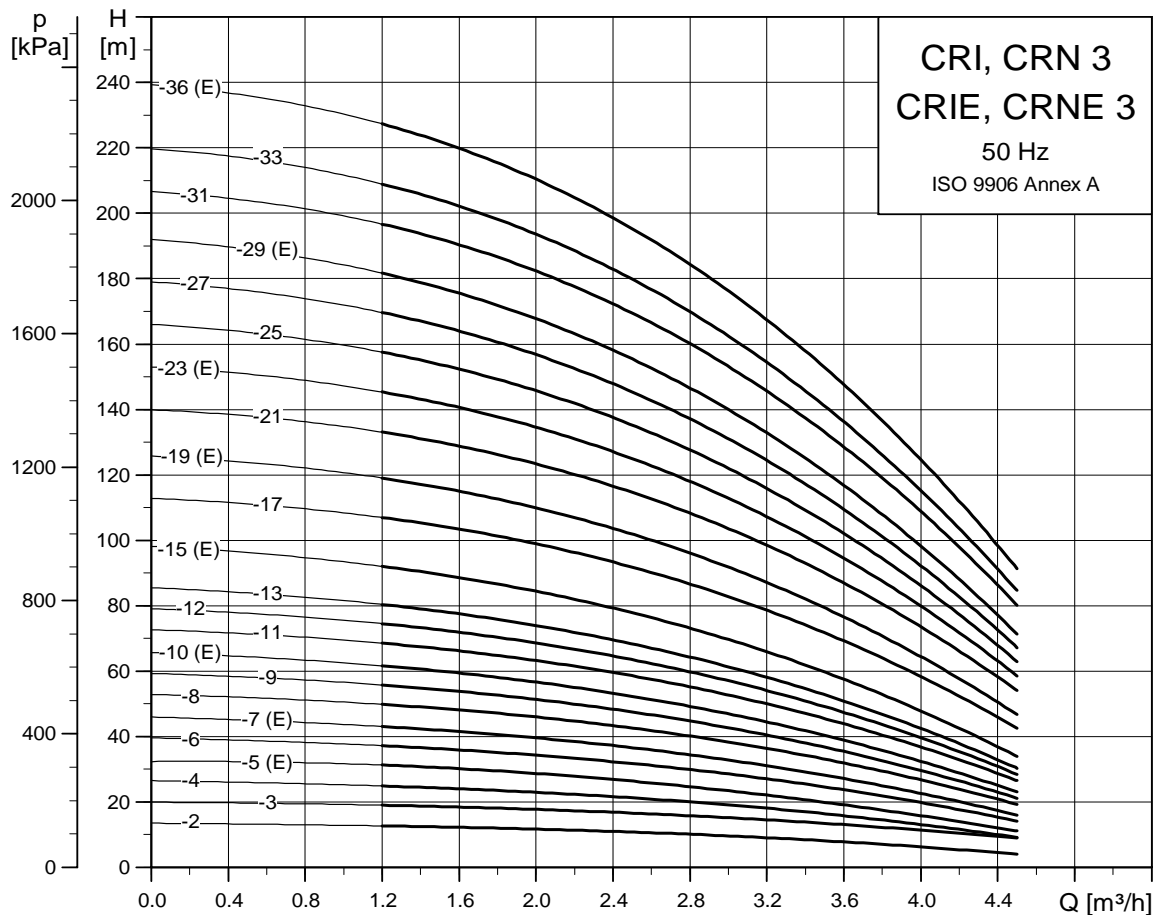

TM02 7293 3605



## Dimensional sketch

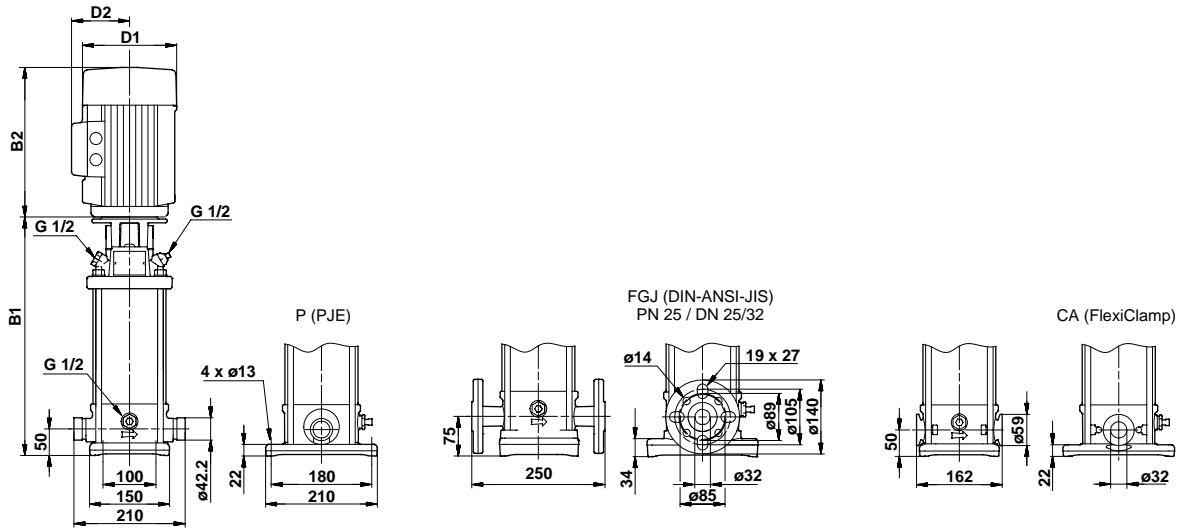

TM03 1722 2805

## Dimensions and weights

Pump type	Motor P <sub>2</sub> [kW]	CRI/CRN								CRIE/CRNE							
		Dimension [mm]						Net weight [kg]		Dimension [mm]						Net weight [kg]	
		PJE/CA		DIN flange		D1	D2	PJE/CA	DIN flange	PJE/CA		DIN flange		D1	D2	PJE/CA	DIN flange
		B1	B1+B2	B1	B1+B2					B1	B1+B2	B1	B1+B2				
CRI/CRN 3-2	0.37	257	448	282	473	141	109	16	19	-	-	-	-	-	-	-	-
CRI/CRN 3-3	0.37	257	448	282	473	141	109	16	19	-	-	-	-	-	-	-	-
CRI/CRN 3-4	0.37	275	466	300	491	141	109	17	19	-	-	-	-	-	-	-	-
CRI(E)/CRN(E) 3-5	0.37	293	484	318	509	141	109	17	20	293	484	318	509	141	140	17.6	21.2
CRI/CRN 3-6	0.55	311	502	336	527	141	109	18	21	-	-	-	-	-	-	-	-
CRI(E)/CRN(E) 3-7	0.55	329	520	354	545	141	109	19	21	329	520	354	545	141	140	19.0	22.6
CRI/CRN 3-8	0.75	353	584	378	609	141	109	21	24	-	-	-	-	-	-	-	-
CRI/CRN 3-9	0.75	371	602	396	627	141	109	22	24	-	-	-	-	-	-	-	-
CRI(E)/CRN(E) 3-10	0.75	389	620	414	645	141	109	22	25	389	620	414	645	178	167	24.1	27.7
CRI/CRN 3-11	1.1	407	638	432	663	141	109	25	27	-	-	-	-	-	-	-	-
CRI/CRN 3-12	1.1	425	656	450	681	141	109	25	28	-	-	-	-	-	-	-	-
CRI/CRN 3-13	1.1	443	674	468	699	141	109	26	28	-	-	-	-	-	-	-	-
CRI(E)/CRN(E) 3-15	1.1	479	710	504	735	141	109	26	29	479	710	504	735	178	167	26.8	30.4
CRI/CRN 3-17	1.5	531	812	556	837	178	110	34	36	-	-	-	-	-	-	-	-
CRI(E)/CRN(E) 3-19	1.5	567	848	592	873	178	110	34	37	567	848	592	873	178	167	39.7	43.3
CRI/CRN 3-21	2.2	603	924	628	949	178	110	36	38	-	-	-	-	-	-	-	-
CRI(E)/CRN(E) 3-23	2.2	639	960	664	985	178	110	37	39	639	960	664	985	178	167	45.3	48.9
CRI/CRN 3-25	2.2	675	996	700	1021	178	110	37	40	-	-	-	-	-	-	-	-
CRI/CRN 3-27	2.2	711	1032	736	1057	178	110	38	41	-	-	-	-	-	-	-	-
CRI(E)/CRN(E) 3-29	2.2	747	1068	772	1093	178	110	39	42	747	1068	772	1093	178	167	47.8	51.4
CRI/CRN 3-31	3.0	787	1122	812	1147	198	120	44	47	-	-	-	-	-	-	-	-
CRI/CRN 3-33	3.0	823	1158	848	1183	198	120	45	47	-	-	-	-	-	-	-	-
CRI(E)/CRN(E) 3-36	3.0	877	1212	902	1237	198	120	46	49	877	1212	902	1237	198	177	55.4	59.0

## CR, CRE 5

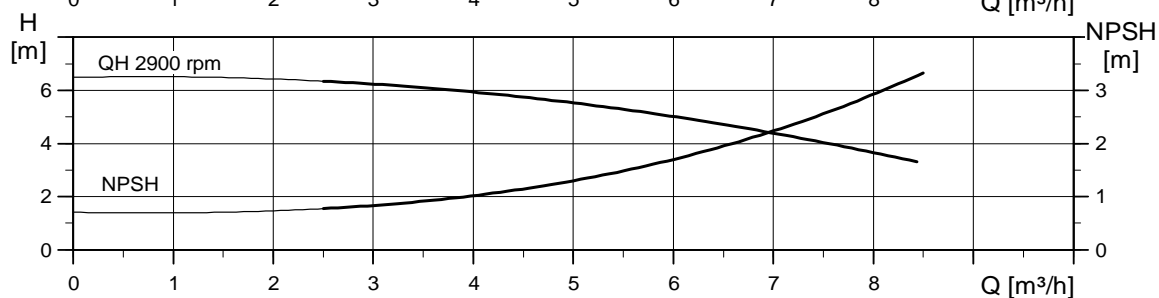
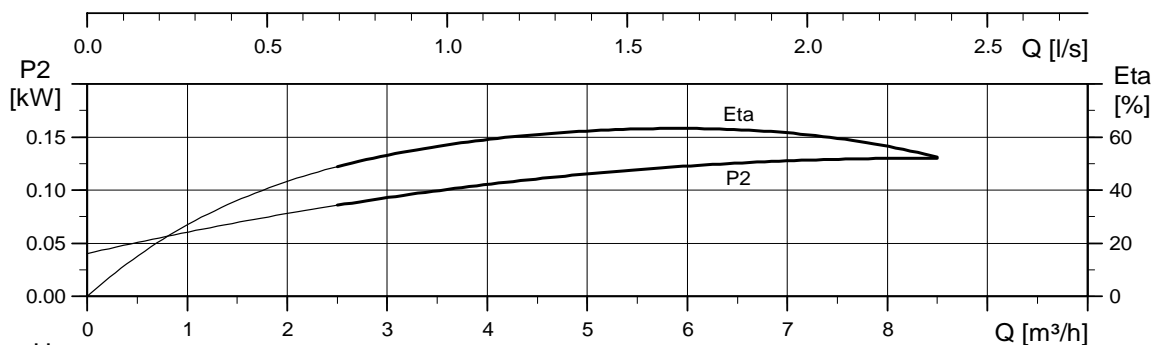
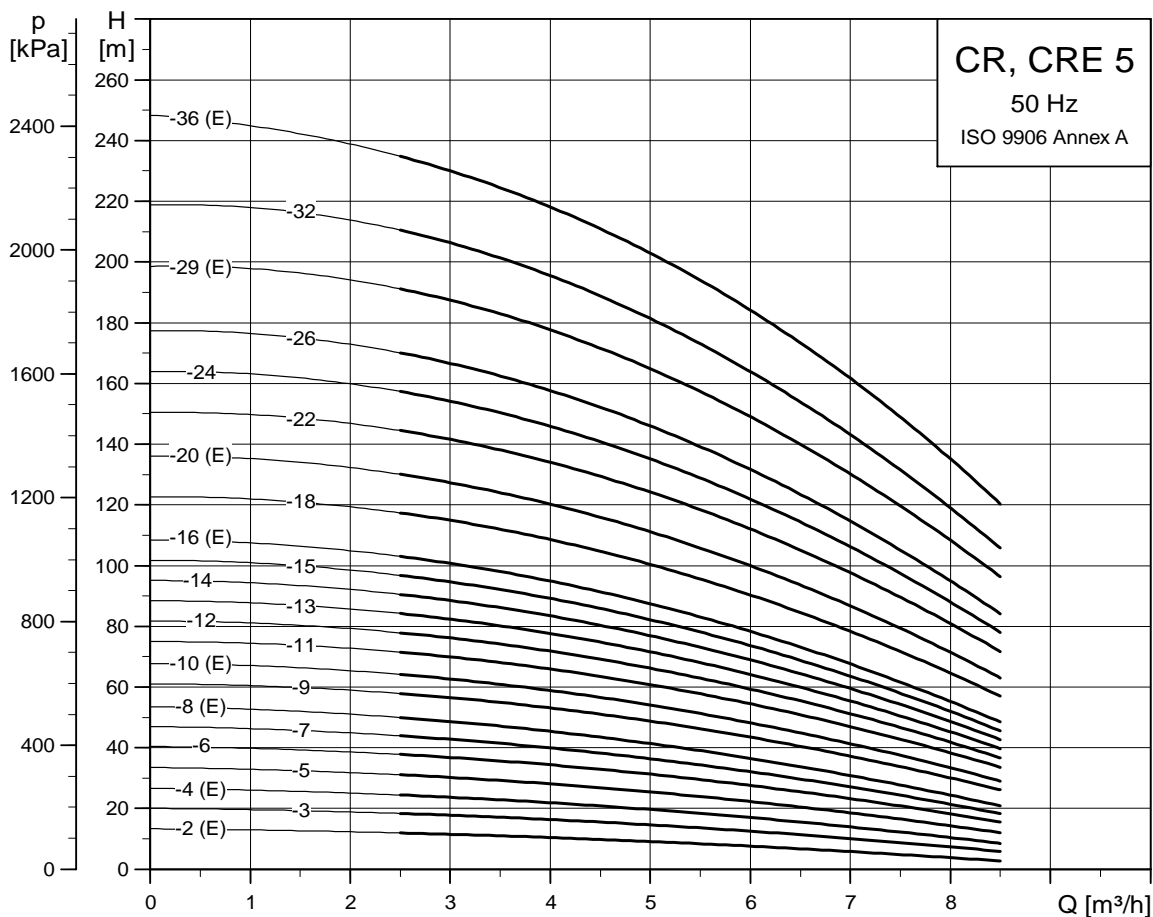

TM02 7294 3605

## Dimensional sketch

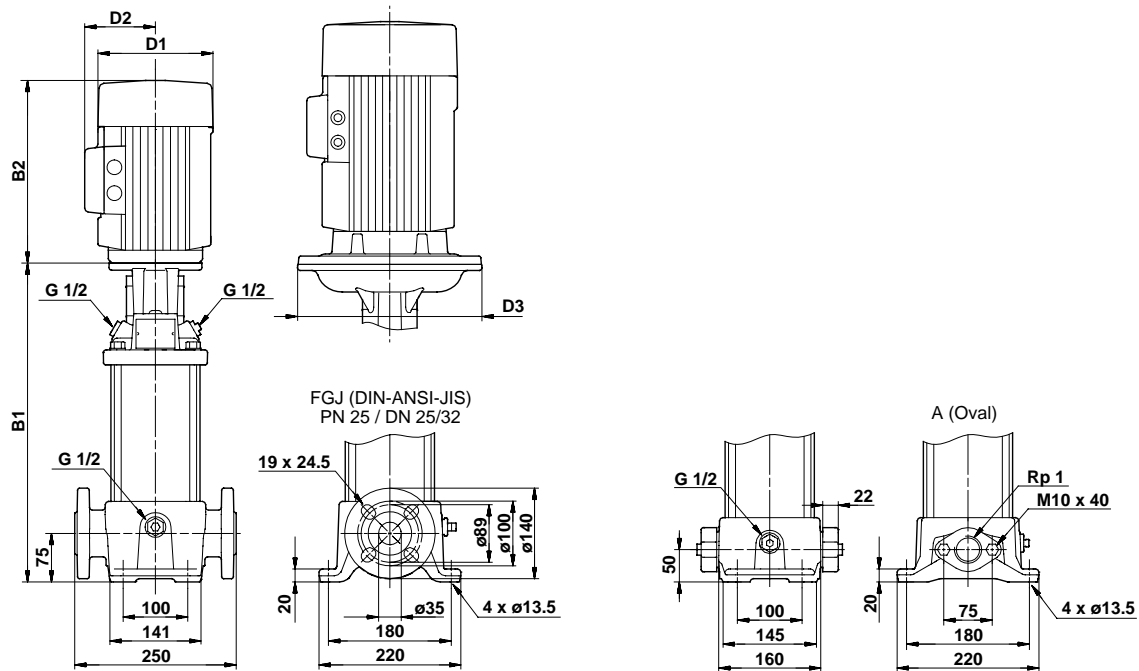

TM03 1723 2805

## Dimensions and weights

Pump type	Motor P <sub>2</sub> [kW]	CR										CRE							
		Dimension [mm]						Net weight [kg]				Dimension [mm]						Net weight [kg]	
		Oval flange		DIN flange		D1	D2	D3	Oval flange	DIN flange	Oval flange		DIN flange		D1	D2	D3	Oval flange	DIN flange
B1	B1+B2	B1	B1+B2							B1	B1+B2	B1	B1+B2						
CR(E) 5-2	0.37	254	445	279	470	141	109	-	18	23	254	445	279	470	141	140	-	19.8	23.9
CR 5-3	0.55	281	472	306	497	141	109	-	20	24	-	-	-	-	-	-	-	-	-
CR(E) 5-4	0.55	308	499	333	524	141	109	-	20	25	308	499	333	524	141	140	-	21.2	25.3
CR 5-5	0.75	341	572	366	597	141	109	-	22	27	-	-	-	-	-	-	-	-	-
CR 5-6	1.1	368	599	393	624	141	109	-	25	30	-	-	-	-	-	-	-	-	-
CR 5-7	1.1	395	626	420	651	141	109	-	26	30	-	-	-	-	-	-	-	-	-
CR(E) 5-8	1.1	422	653	447	678	141	109	-	26	31	422	653	447	678	178	167	-	28.8	32.9
CR 5-9	1.5	465	746	490	771	178	110	-	34	38	-	-	-	-	-	-	-	-	-
CR(E) 5-10	1.5	492	773	517	798	178	110	-	34	39	492	773	517	798	178	167	-	41.3	45.4
CR 5-11	2.2	519	840	544	865	178	110	-	36	40	-	-	-	-	-	-	-	-	-
CR 5-12	2.2	546	867	571	892	178	110	-	36	41	-	-	-	-	-	-	-	-	-
CR 5-13	2.2	573	894	598	919	178	110	-	37	41	-	-	-	-	-	-	-	-	-
CR 5-14	2.2	600	921	625	946	178	110	-	37	42	-	-	-	-	-	-	-	-	-
CR 5-15	2.2	627	948	652	973	178	110	-	38	43	-	-	-	-	-	-	-	-	-
CR(E) 5-16	2.2	654	975	679	1000	178	110	-	38	43	654	975	679	1000	178	167	-	48.5	52.6
CR 5-18	3.0	712	1047	737	1072	198	120	-	44	48	-	-	-	-	-	-	-	-	-
CR(E) 5-20	3.0	766	1101	791	1126	198	120	-	45	50	766	1101	791	1126	198	177	-	55.1	59.2
CR 5-22	4.0	820	1194	845	1217	220	134	-	56	62	-	-	-	-	-	-	-	-	-
CR 5-24	4.0	-	-	899	1271	220	134	-	-	63	-	-	-	-	-	-	-	-	-
CR 5-26	4.0	-	-	953	1325	220	134	-	-	64	-	-	-	-	-	-	-	-	-
CR(E) 5-29	4.0	-	-	1034	1406	220	134	-	-	66	-	-	1034	1406	220	188	-	-	76.5
CR 5-32	5.5	-	-	1145	1536	220	134	300	-	82	-	-	-	-	-	-	-	-	-
CR(E) 5-36	5.5	-	-	1253	1644	220	134	300	-	84	-	-	1253	1644	220	188	-	-	95.5

## CRI, CRN, CRIE, CRNE 5

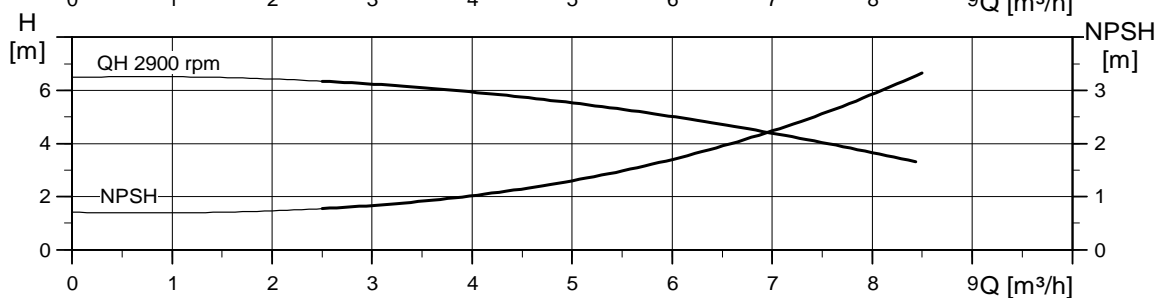
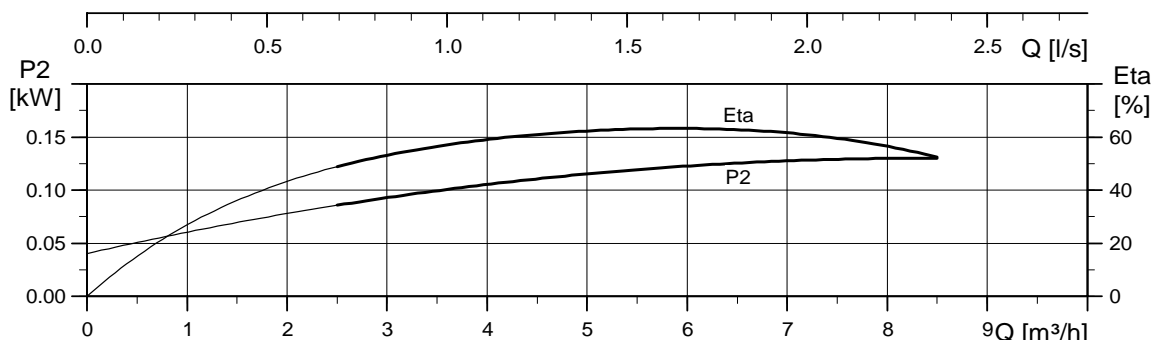
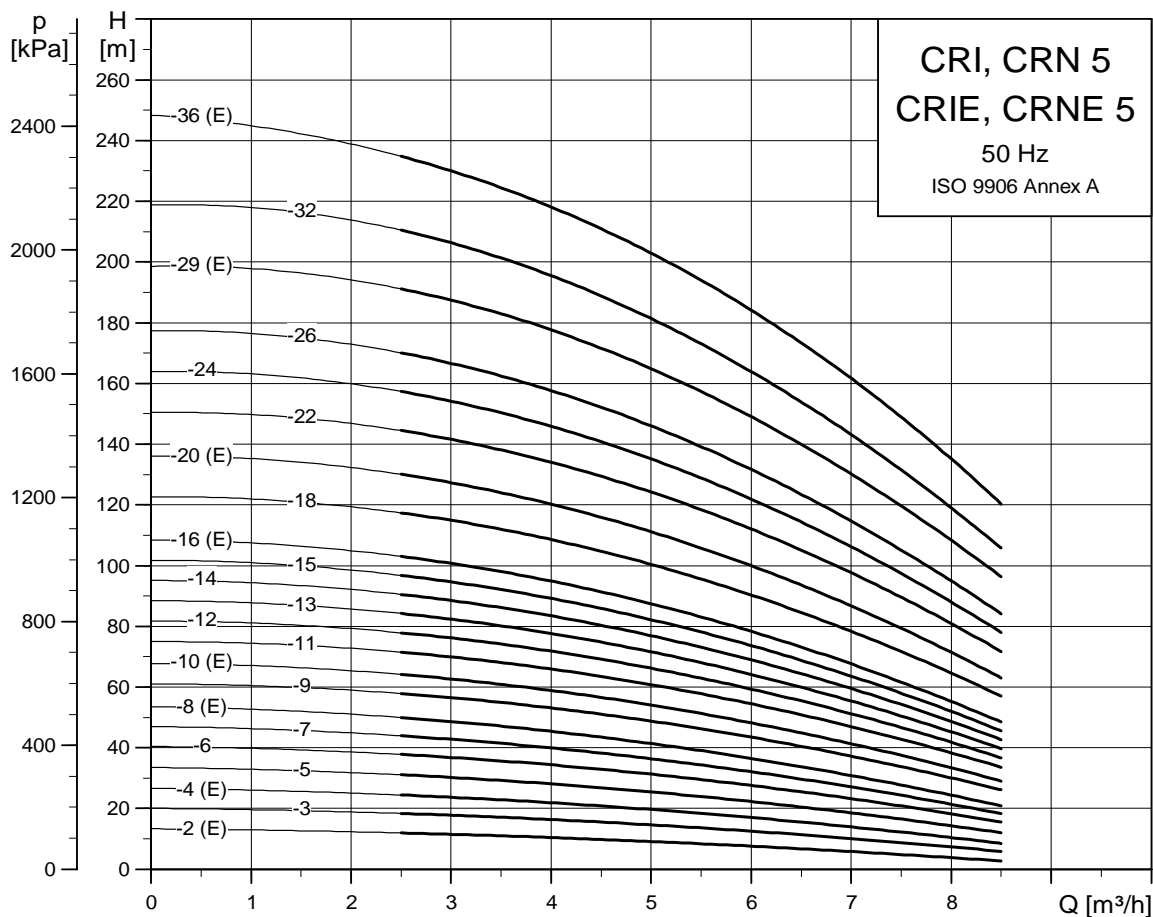

TM02 7295 3605

## Dimensional sketch

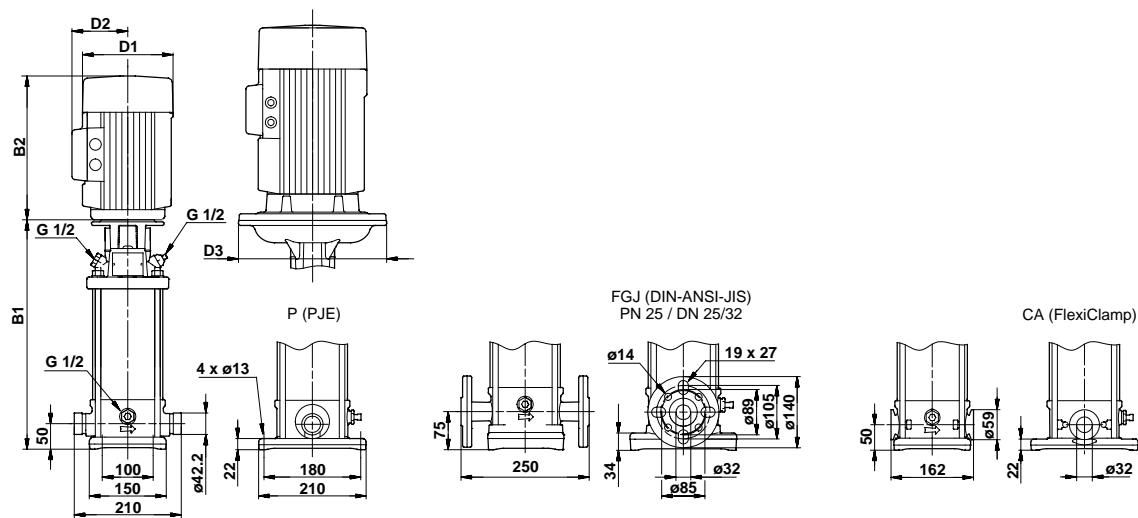

TM03 1724 2805

## Dimensions and weights

Pump type	Motor P <sub>2</sub> [kW]	CRI/CRN										CRIE/CRNE							
		Dimension [mm]						Net weight [kg]				Dimension [mm]						Net weight [kg]	
		PJE/CA		DIN flange		D1	D2	D3	PJE/CA	DIN flange	PJE/CA		DIN flange		D1	D2	D3	PJE/CA	DIN flange
		B1	B1+B2	B1	B1+B2						B1	B1+B2	B1	B1+B2					
CRI(E)/CRN(E) 5-2	0.37	257	448	282	473	141	109	-	16	21	257	448	282	473	141	140	-	17.0	20.6
CRI/CRN 5-3	0.55	284	475	309	500	141	109	-	18	22	-	-	-	-	-	-	-	-	-
CRI(E)/CRN(E) 5-4	0.55	311	502	336	527	141	109	-	18	22	311	502	336	527	141	140	-	18.4	22.0
CRI/CRN 5-5	0.75	344	575	369	600	141	109	-	21	25	-	-	-	-	-	-	-	-	-
CRI/CRN 5-6	1.1	371	602	396	627	141	109	-	24	28	-	-	-	-	-	-	-	-	-
CRI/CRN 5-7	1.1	398	629	423	654	141	109	-	24	28	-	-	-	-	-	-	-	-	-
CRI(E)/CRN(E) 5-8	1.1	425	656	450	681	141	109	-	25	29	425	656	450	681	178	167	-	26.0	29.6
CRI/CRN 5-9	1.5	468	749	493	774	178	110	-	32	36	-	-	-	-	-	-	-	-	-
CRI(E)/CRN(E) 5-10	1.5	495	776	520	801	178	110	-	32	37	495	776	520	801	178	167	-	38.5	42.1
CRI/CRN 5-11	2.2	522	843	547	868	178	110	-	34	38	-	-	-	-	-	-	-	-	-
CRI/CRN 5-12	2.2	549	870	574	895	178	110	-	34	38	-	-	-	-	-	-	-	-	-
CRI/CRN 5-13	2.2	576	897	601	922	178	110	-	35	39	-	-	-	-	-	-	-	-	-
CRI/CRN 5-14	2.2	603	924	628	949	178	110	-	35	40	-	-	-	-	-	-	-	-	-
CRI/CRN 5-15	2.2	630	951	655	976	178	110	-	36	40	-	-	-	-	-	-	-	-	-
CRI(E)/CRN(E) 5-16	2.2	657	978	682	1003	178	110	-	36	41	657	978	682	1003	178	167	-	45.7	49.3
CRI/CRN 5-18	3.0	715	1050	740	1075	198	120	-	42	46	-	-	-	-	-	-	-	-	-
CRI(E)/CRN(E) 5-20	3.0	769	1104	794	1129	198	120	-	43	47	769	1104	794	1129	198	177	-	52.3	55.9
CRI/CRN 5-22	4.0	823	1195	848	1220	220	134	-	55	59	-	-	-	-	-	-	-	-	-
CRI/CRN 5-24	4.0	877	1249	902	1274	220	134	-	56	61	-	-	-	-	-	-	-	-	-
CRI/CRN 5-26	4.0	931	1303	956	1328	220	134	-	58	62	-	-	-	-	-	-	-	-	-
CRI(E)/CRN(E) 5-29	4.0	1012	1384	1037	1409	220	134	-	59	64	1012	1384	1037	1409	220	188	-	69.6	73.2
CRI/CRN 5-32	5.5	1123	1514	1148	1539	220	134	300	75	79	-	-	-	-	-	-	-	-	-
CRI(E)/CRN(E) 5-36	5.5	1231	1622	1256	1647	220	134	300	77	81	1231	1622	1256	1647	220	188	-	88.6	92.2

## CR, CRE 10

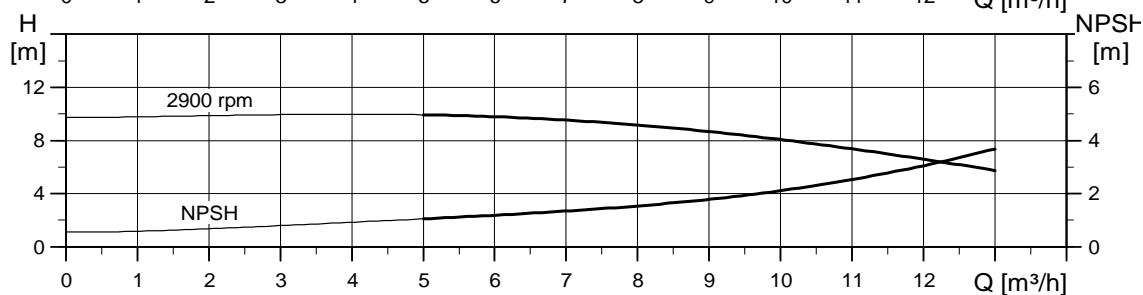
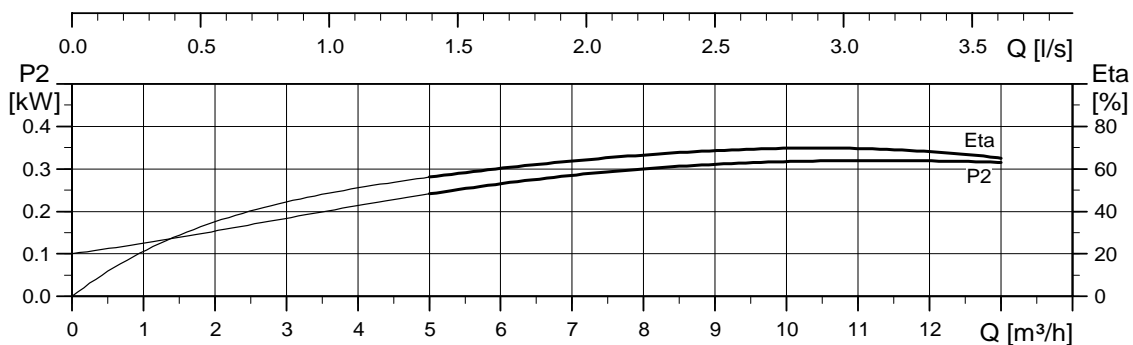
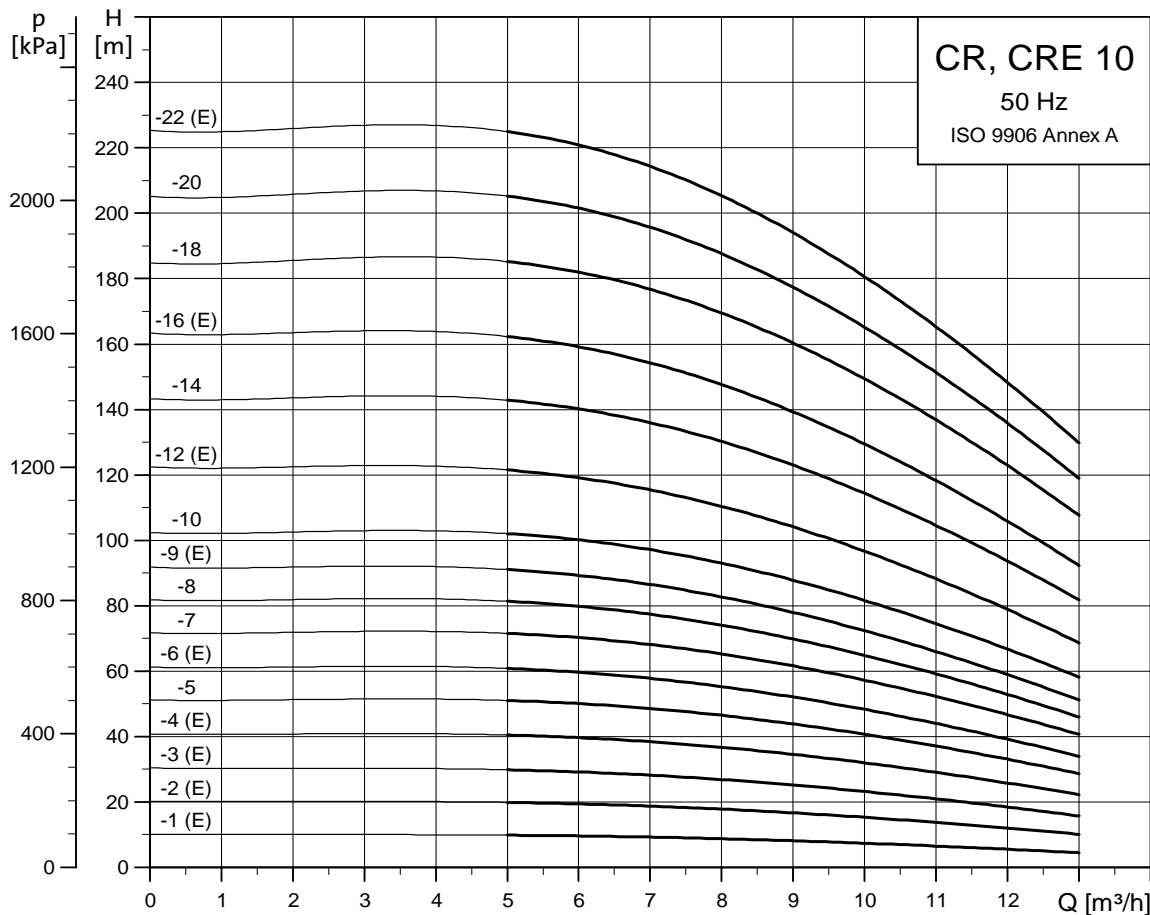

TM02 7296 3605

## Dimensional sketch

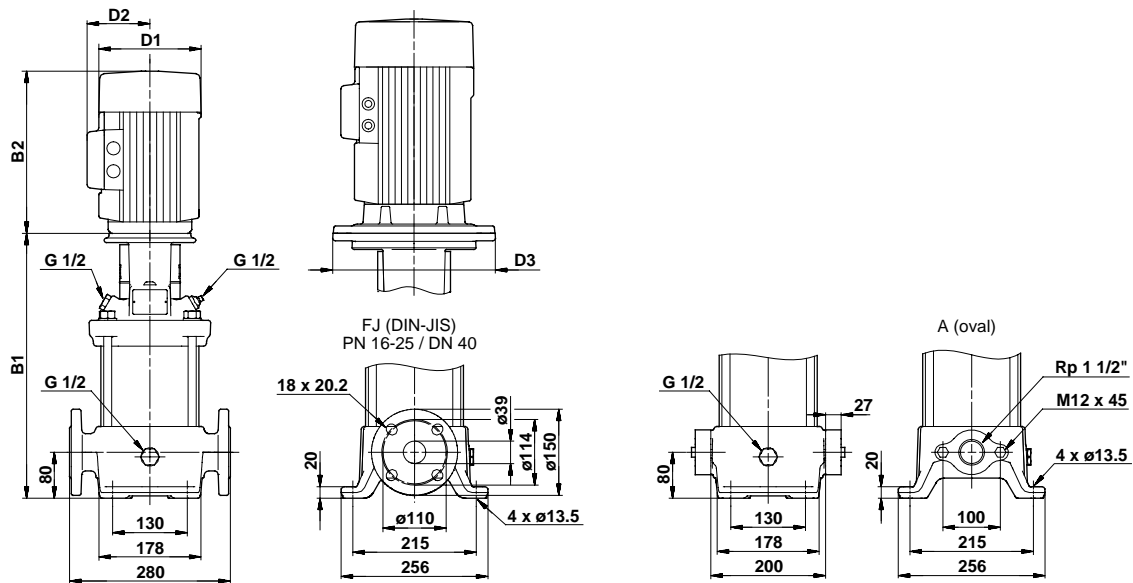

TM03 1725 2805

## Dimensions and weights

Pump type	Motor P <sub>2</sub> [kW]	CR										CRE									
		Dimension [mm]								Net weight [kg]		Dimension [mm]								Net weight [kg]	
		Oval flange				DIN flange				Oval flange	DIN flange	Oval flange				DIN flange				Oval flange	DIN flange
		B1	B1+B2	B1	B1+B2	D1	D2	D3	B1			B1+B2	B1	B1+B2	D1	D2	D3	B1	B1+B2		
CR(E) 10-1	0.37	343	534	343	534	141	109	-	31	34	343	534	343	534	141	140	-	32.9	35.9		
CR(E) 10-2	0.75	347	578	347	578	141	109	-	34	36	347	347	347	347	178	167	-	35.2	37.2		
CR(E) 10-3	1.1	377	608	377	608	141	109	-	37	39	377	608	377	608	178	167	-	32.9	35.9		
CR(E) 10-4	1.5	423	704	423	704	178	110	-	45	47	423	704	423	704	178	167	-	54.5	51.5		
CR 10-5	2.2	453	734	453	734	178	110	-	46	49	-	-	-	-	-	-	-	-	-		
CR(E) 10-6	2.2	483	764	483	764	178	110	-	47	50	483	764	483	764	178	167	-	57.5	60.5		
CR 10-7	3.0	518	853	518	853	198	120	-	52	55	-	-	-	-	-	-	-	-	-		
CR 10-8	3.0	548	883	548	883	198	120	-	53	56	-	-	-	-	-	-	-	-	-		
CR(E) 10-9	3.0	578	913	578	913	198	120	-	54	57	578	913	578	913	198	177	-	63.0	66.0		
CR 10-10	4.0	608	980	608	980	220	134	-	66	69	-	-	-	-	-	-	-	-	-		
CR(E) 10-12	4.0	668	1040	668	1040	220	134	-	69	71	668	1040	668	1040	220	188	-	78.3	81.3		
CR 10-14	5.5	760	1151	760	1151	220	134	300	91	94	-	-	-	-	-	-	-	-	-		
CR(E) 10-16	5.5	820	1211	820	1211	220	134	300	93	96	820	1211	820	1211	220	188	298	104.9	107.9		
CR 10-18	7.5	-	-	880	1271	220	134	300	-	101	-	-	-	-	-	-	-	-	-		
CR 10-20	7.5	-	-	940	1331	220	134	300	-	103	-	-	-	-	-	-	-	-	-		
CR(E) 10-22	7.5	-	-	1000	1391	220	134	300	-	105	-	-	1000	1391	220	188	298	-	116.7		

## CRI, CRN, CRIE, CRNE 10

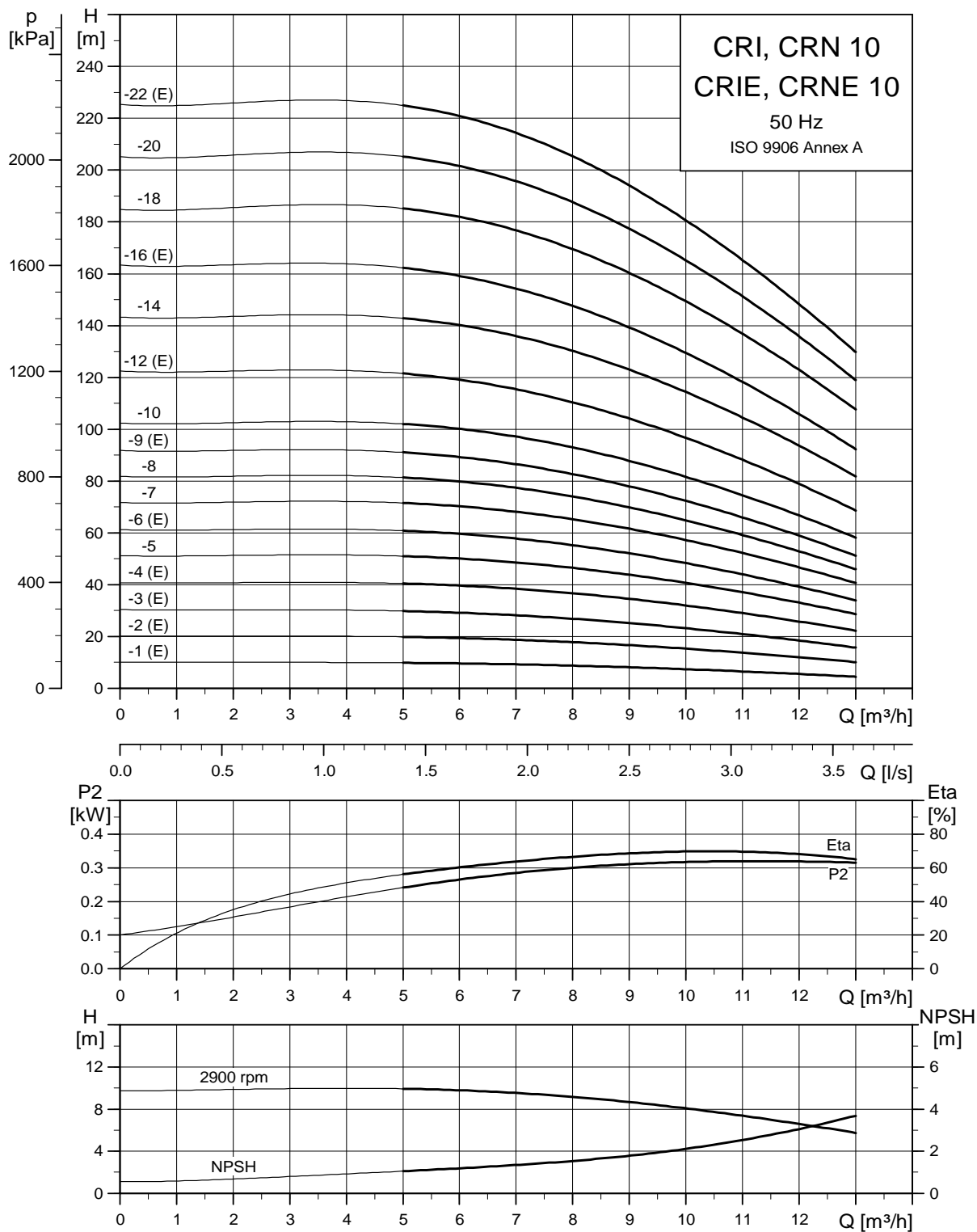

TM02 7297 3605



## Dimensional sketch

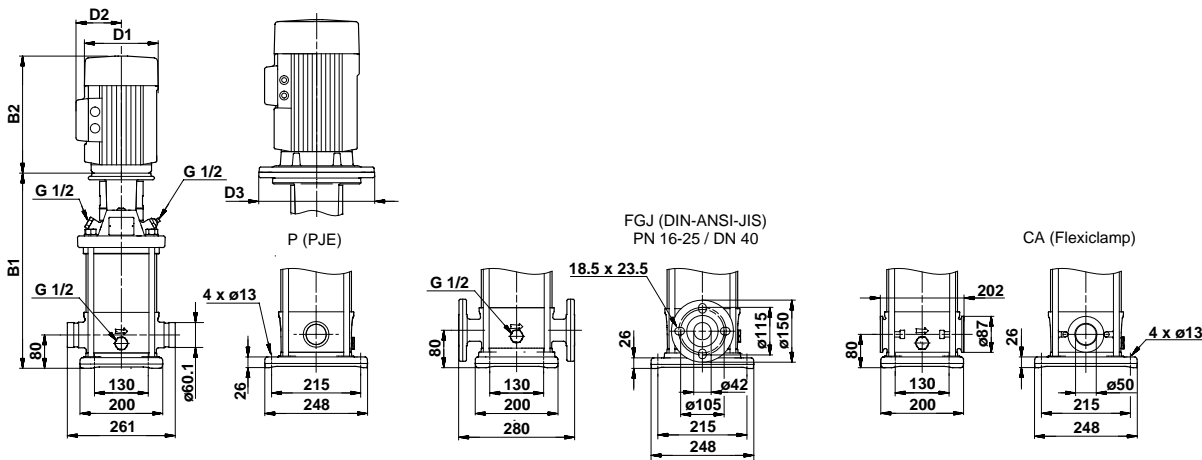

## Dimensions and weights

Pump type	Motor P <sub>2</sub> [kW]	CRI/CRN										CRIE/CRNE								
		Dimension [mm]									Net weight [kg]		Dimension [mm]						Net weight [kg]	
		PJE/CA		DIN flange		D1	D2	D3	PJE/CA	DIN flange	PJE/CA		DIN flange		D1	D2	D3	PJE/CA	DIN flange	
		B1	B1+B2	B1	B1+B2						B1	B1+B2	B1	B1+B2						
CRI(E)/CRN(E) 10-1	0.37	353	544	353	544	141	109	-	28	32	353	544	353	544	141	140	-	29.9	33.9	
CRI(E)/CRN(E) 10-2	0.75	357	588	357	588	141	109	-	31	34	357	588	357	588	178	167	-	32.2	35.2	
CRI(E)/CRN(E) 10-3	1.1	387	618	387	618	141	109	-	34	38	387	618	387	618	178	167	-	29.9	33.9	
CRI(E)/CRN(E) 10-4	1.5	433	714	433	714	178	110	-	42	46	433	714	433	714	178	167	-	48.5	52.5	
CRI/CRN 10-5	2.2	463	784	463	784	178	110	-	44	47	-	-	-	-	-	-	-	-	-	
CRI(E)/CRN(E) 10-6	2.2	493	814	493	814	178	110	-	45	48	493	814	493	814	178	167	-	55.5	58.5	
CRI/CRN 10-7	3.0	528	863	528	863	198	120	-	50	54	-	-	-	-	-	-	-	-	-	
CRI/CRN 10-8	3.0	558	893	558	893	198	120	-	51	55	-	-	-	-	-	-	-	-	-	
CRI(E)/CRN(E) 10-9	3.0	588	923	588	923	198	120	-	52	56	588	923	588	923	198	177	-	61.0	65.0	
CRI/CRN 10-10	4.0	618	990	618	990	220	134	-	64	68	-	-	-	-	-	-	-	-	-	
CRI(E)/CRN(E) 10-12	4.0	678	1050	678	1050	220	134	-	66	70	678	1050	678	1050	220	188	-	76.3	79.3	
CRI/CRN 10-14	5.5	770	1161	770	1161	220	134	300	88	92	-	-	-	-	-	-	-	-	-	
CRI(E)/CRN(E) 10-16	5.5	830	1221	830	1221	220	134	300	90	94	830	1221	830	1221	220	188	300	102.9	105.9	
CRI/CRN 10-18	7.5	890	1281	890	1281	220	134	300	96	99	-	-	-	-	-	-	-	-	-	
CRI/CRN 10-20	7.5	950	1341	950	1341	220	134	300	98	101	-	-	-	-	-	-	-	-	-	
CRI(E)/CRN(E) 10-22	7.5	1010	1401	1010	1401	220	134	300	100	104	1010	1401	1010	1401	220	188	298	110.7	114.7	

TM03 2498 4405

## CR, CRE 15

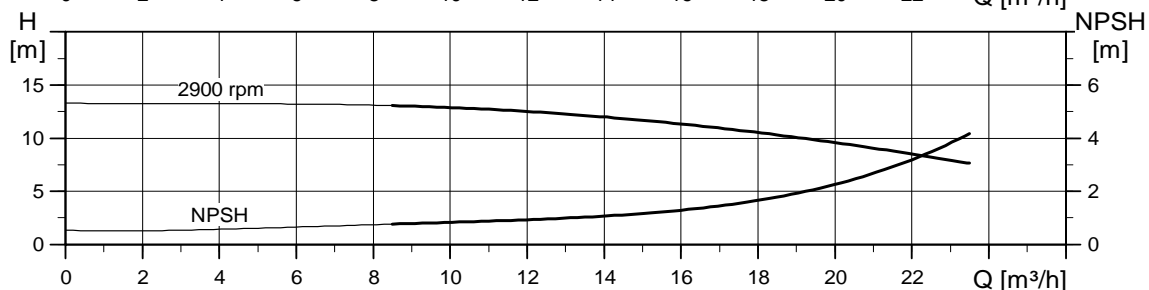
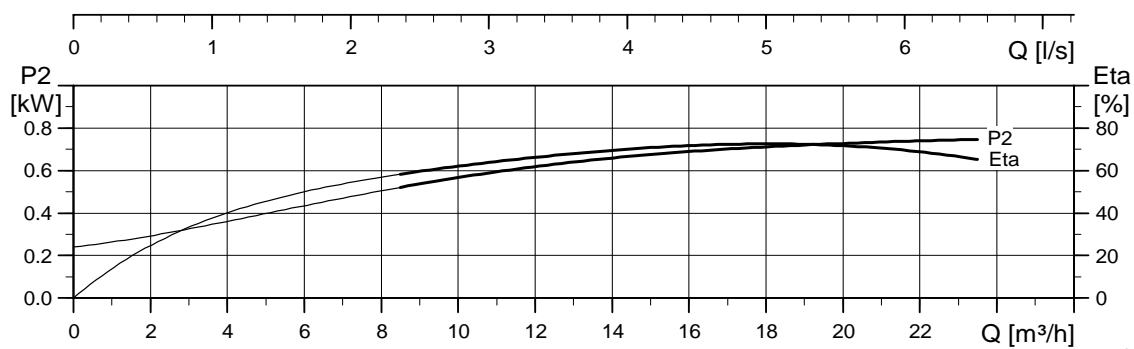
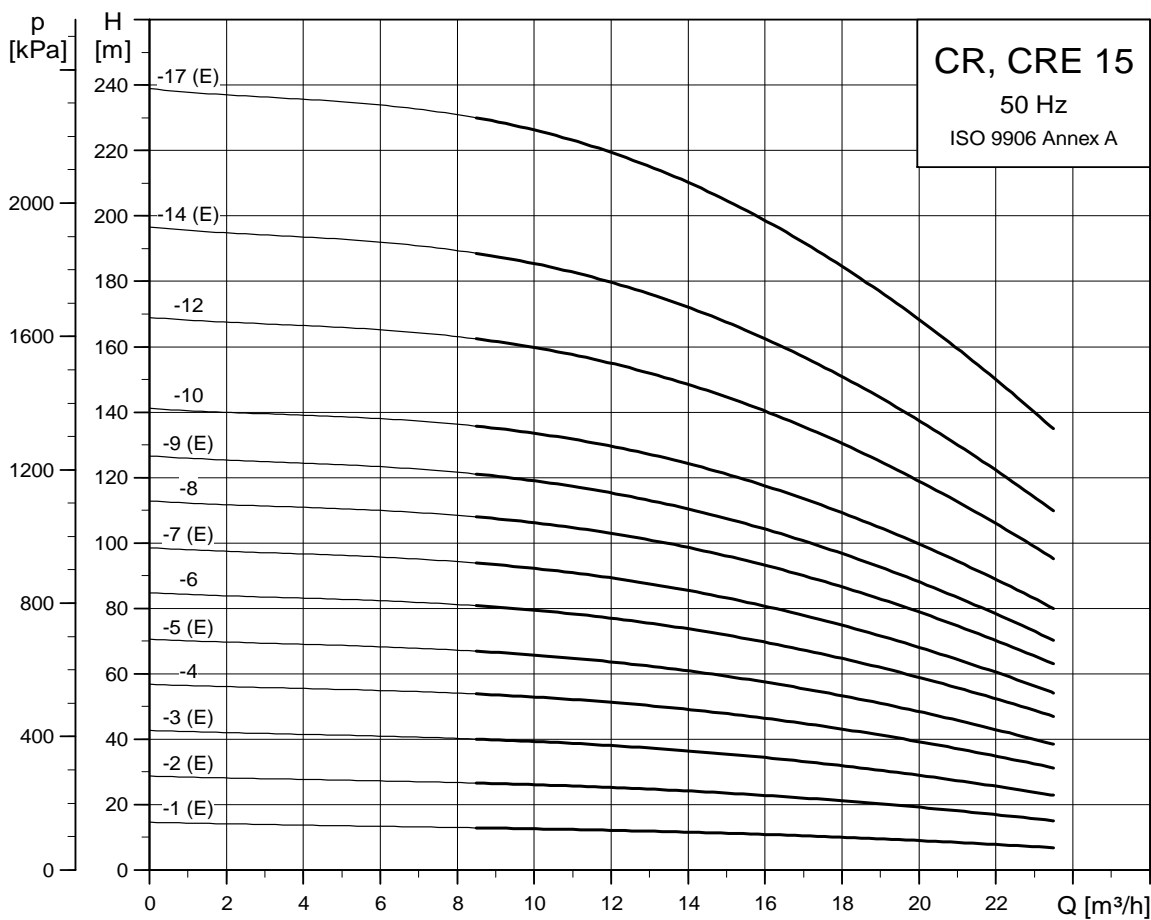

TM02 7296 3605

## Dimensional sketch

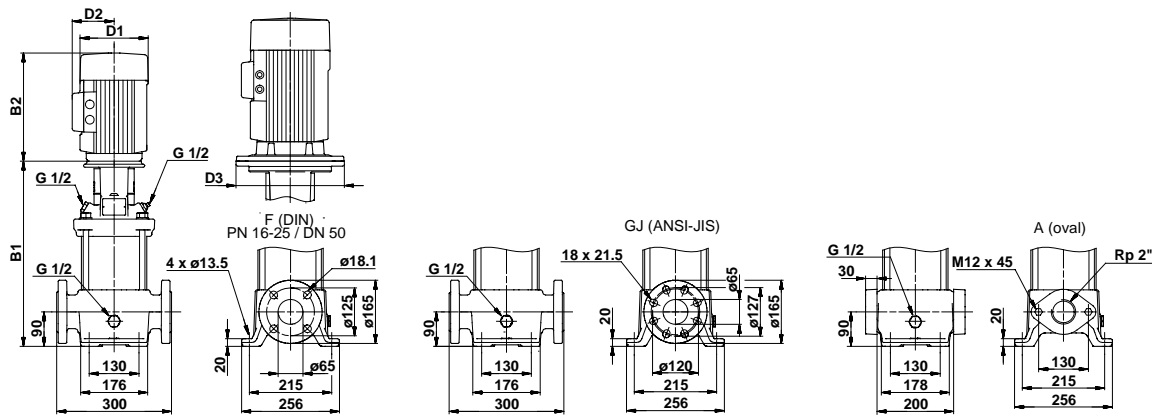

TM03 1727 2805

## Dimensions and weights

Pump type	Motor P <sub>2</sub> [kW]	CR									CRE								
		Dimension [mm]						Net weight [kg]			Dimension [mm]						Net weight [kg]		
		Oval flange		DIN flange		D1	D2	D3	Oval flange	DIN flange	Oval flange		DIN flange		D1	D2	D3	Oval flange	DIN flange
		B1	B1+B2	B1	B1+B2						B1	B1+B2	B1	B1+B2					
CR(E) 15-1	1.1	400	631	400	631	141	109	-	41	42	400	631	400	631	178	167	-	36.9	37.9
CR(E) 15-2	2.2	415	736	415	736	178	110	-	49	50	415	736	415	736	178	167	-	59.5	60.5
CR(E) 15-3	3.0	465	800	465	800	198	120	-	54	55	465	800	465	800	198	177	-	63.0	64.0
CR 15-4	4.0	510	882	510	882	220	134	-	67	68	-	-	-	-	-	-	-	-	-
CR(E) 15-5	4.0	555	927	555	927	220	134	-	68	69	555	927	555	927	220	188	-	78.3	79.3
CR 15-6	5.5	632	1023	632	1023	220	134	300	90	91	-	-	-	-	-	-	-	-	-
CR(E) 15-7	5.5	677	1068	677	1068	220	134	300	92	93	677	1068	677	1068	220	188	298	103.9	104.9
CR 15-8	7.5	-	-	722	1113	220	134	300	-	97	-	-	-	-	-	-	-	-	-
CR(E) 15-9	7.5	-	-	767	1158	220	134	300	-	98	-	-	767	1158	220	188	298	-	108.7
CR 15-10	11.0	-	-	889	1388	260	172	350	-	130	-	-	-	-	-	-	-	-	-
CR 15-12	11.0	-	-	979	1478	260	172	350	-	134	-	-	-	-	-	-	-	-	-
CR(E) 15-14	11.0	-	-	1069	1568	260	172	350	-	138	-	-	1069	1518	258	359	350	-	188.0
CR(E) 15-17	15.0	-	-	1204	1682	320	197	350	-	157	-	-	1204	1665	313	377	350	-	190.5

## CRI, CRN, CRIE, CRNE 15

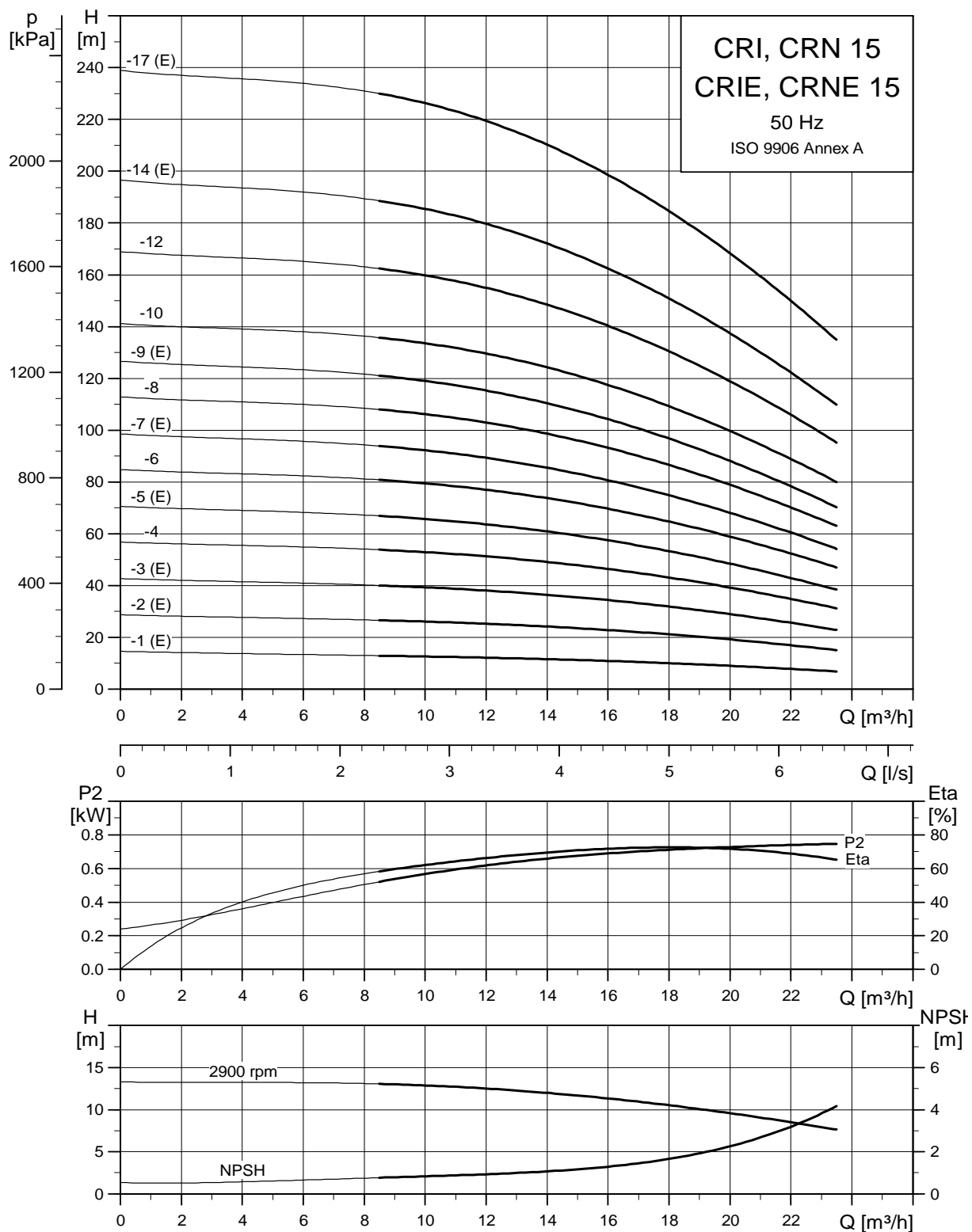

TM02 7299 3605

## Dimensional sketch

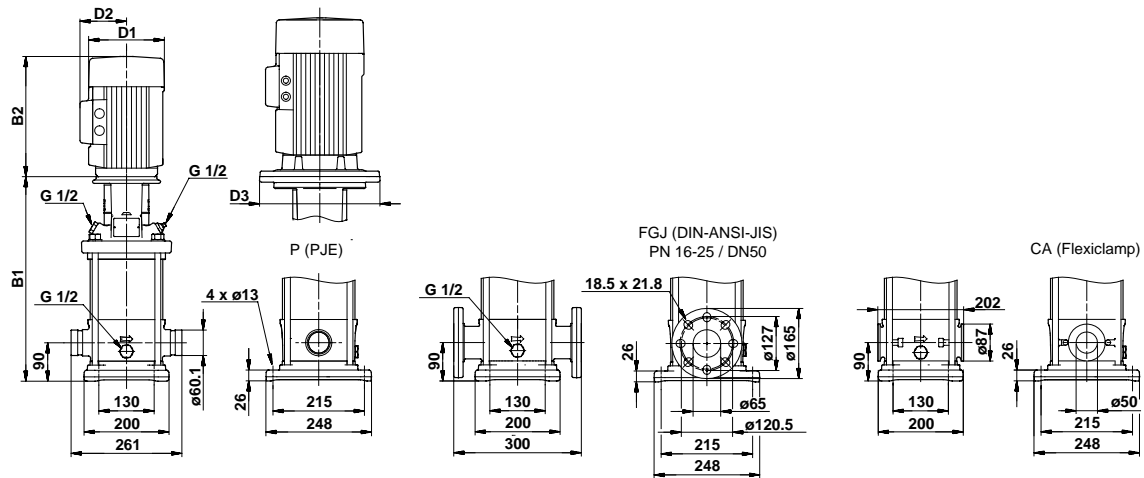

TM03 1728 2805

## Dimensions and weights

Pump type	Motor P <sub>2</sub> [kW]	CRI/CRN										CRIE/CRNE								
		Dimension [mm]									Net weight [kg]		Dimension [mm]						Net weight [kg]	
		PJE/CA		DIN flange		D1	D2	D3	PJE/CA	DIN flange	PJE/CA		DIN flange		D1	D2	D3	PJE/CA	DIN flange	
		B1	B1+B2	B1	B1+B2						B1	B1+B2	B1	B1+B2						
CRI(E)/CRN(E) 15-1	1.1	397	628	400	631	141	109	-	34	42	397	628	400	631	178	167	-	29.9	34.9	
CRI(E)/CRN(E) 15-2	2.2	413	734	415	736	178	110	-	42	50	413	734	415	736	178	167	-	52.5	57.5	
CRI(E)/CRN(E) 15-3	3.0	463	798	465	800	198	120	-	48	55	463	798	465	800	198	177	-	57.0	61.0	
CRI/CRN 15-4	4.0	508	880	510	882	220	134	-	60	68	-	-	-	-	-	-	-	-	-	
CRI(E)/CRN(E) 15-5	4.0	553	925	555	927	220	134	-	62	69	553	925	555	927	220	188	-	71.3	76.3	
CRI/CRN 15-6	5.5	630	1021	632	1023	220	134	300	83	91	-	-	-	-	-	-	-	-	-	
CRI(E)/CRN(E) 15-7	5.5	675	1066	677	1068	220	134	300	85	93	675	1066	677	1068	220	188	298	96.9	100.9	
CRI/CRN 15-8	7.5	720	1111	722	1113	220	134	300	89	97	-	-	-	-	-	-	-	-	-	
CRI(E)/CRN(E) 15-9	7.5	765	1156	767	1158	220	134	300	90	98	765	1156	767	1158	220	188	298	100.7	105.7	
CRI/CRN 15-10	11.0	887	1386	889	1388	260	172	350	122	130	-	-	-	-	-	-	-	-	-	
CRI/CRN 15-12	11.0	977	1476	979	1478	260	172	350	126	134	-	-	-	-	-	-	-	-	-	
CRI(E)/CRN(E) 15-14	11.0	1067	1566	1069	1568	260	172	350	130	138	1067	1516	1069	1518	258	359	350	180.0	185.0	
CRI(E)/CRN(E) 15-17	15.0	1202	1680	1204	1682	320	197	350	149	157	1202	1663	1204	1665	313	377	350	181.5	186.5	

## CR, CRE 20

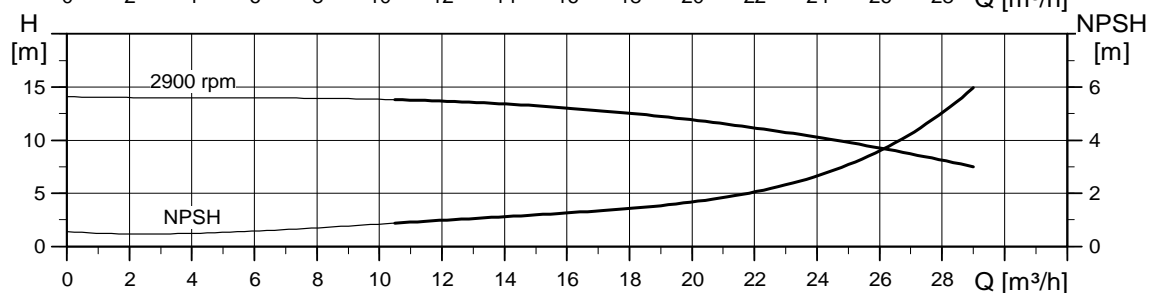
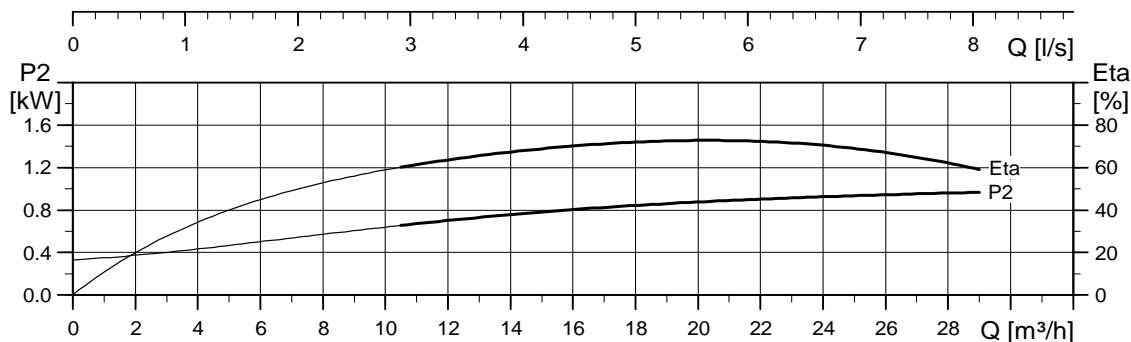
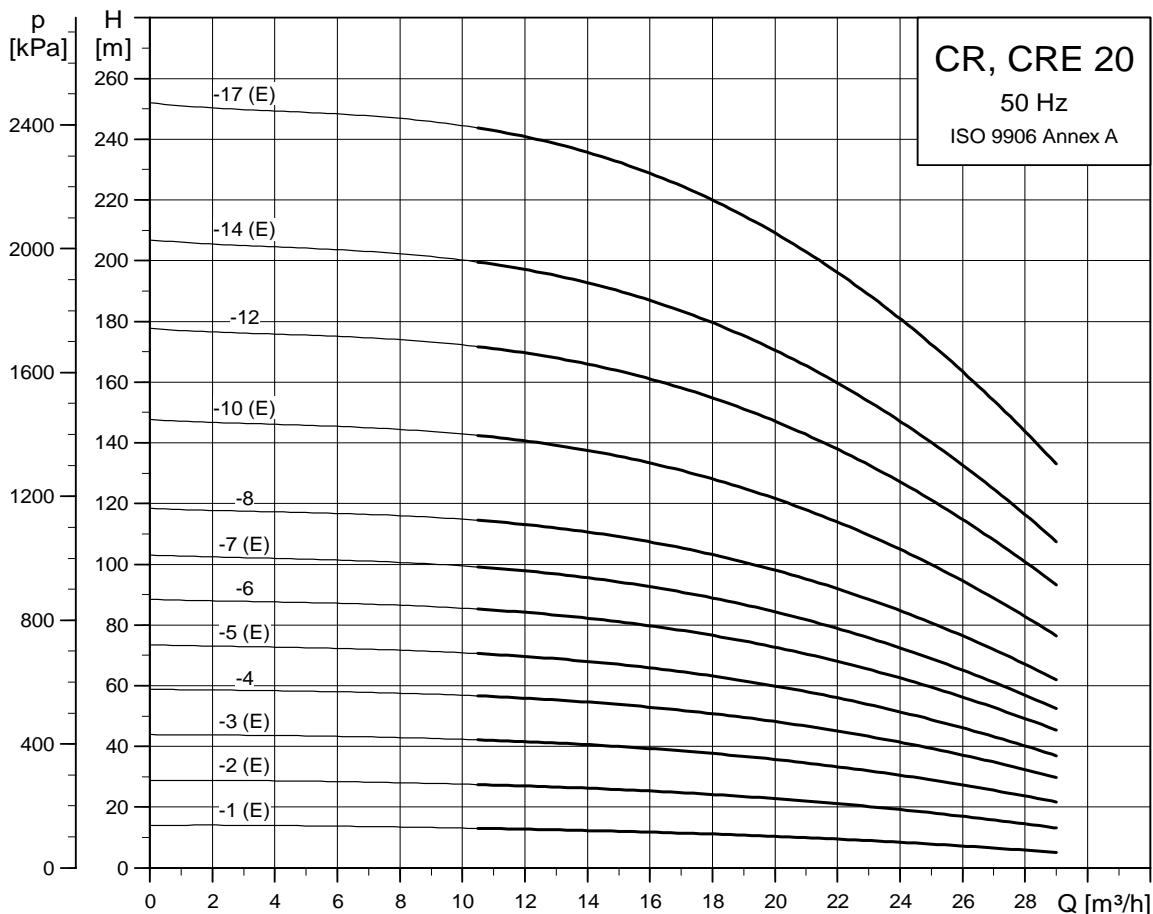

TM02 7300 3605

## Dimensional sketch

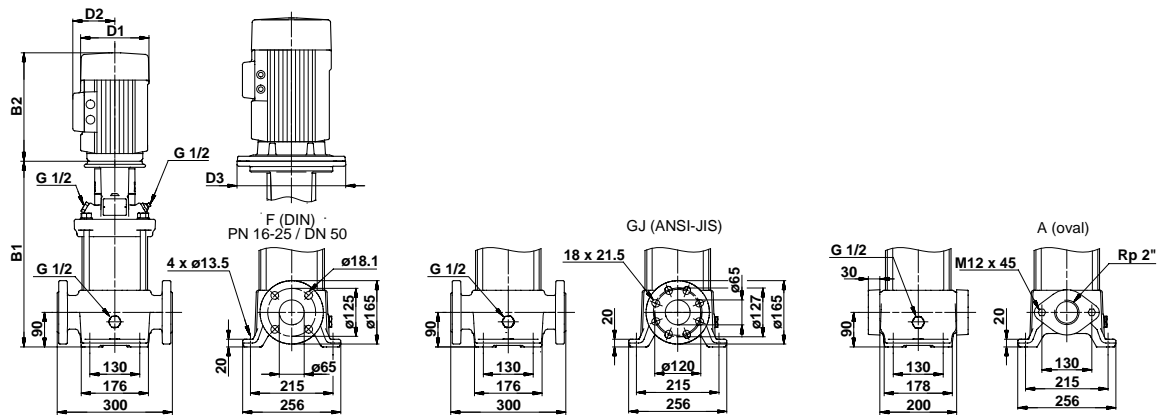

TM03 1727 2805

## Dimensions and weights

Pump type	Motor P <sub>2</sub> [kW]	CR									CRE								
		Dimension [mm]						Net weight [kg]			Dimension [mm]						Net weight [kg]		
		Oval flange		DIN flange		D1	D2	D3	Oval flange	DIN flange	Oval flange		DIN flange		D1	D2	D3	Oval flange	DIN flange
B1	B1+B2	B1	B1+B2	B1	B1+B2						B1	B1+B2	B1	B1+B2					
CR(E) 20-1	1.1	400	631	400	631	141	109	-	41	42	400	631	400	631	178	167	-	36.9	37.9
CR(E) 20-2	2.2	415	736	415	736	178	110	-	49	50	415	736	415	736	178	167	-	65.8	66.8
CR(E) 20-3	4.0	465	837	465	837	220	134	-	65	66	465	837	465	837	220	188	-	75.3	76.3
CR 20-4	5.5	542	933	542	933	220	134	300	87	88	-	-	-	-	-	-	-	-	-
CR(E) 20-5	5.5	587	978	587	978	220	134	300	89	90	587	978	587	978	220	188	298	100.9	101.9
CR 20-6	7.5	632	1023	632	1023	220	134	300	92	93	-	-	-	-	-	-	-	-	-
CR(E) 20-7	7.5	677	1068	677	1068	220	134	300	94	95	677	1068	677	1068	220	188	298	104.7	105.7
CR 20-8	11.0	-	-	799	1298	260	172	350	-	127	-	-	-	-	-	-	-	-	-
CR(E) 20-10	11.0	-	-	889	1388	260	172	350	-	130	-	-	889	1338	258	359	350	-	181.0
CR 20-12	15.0	-	-	979	1457	320	197	350	-	148	-	-	-	-	-	-	-	-	-
CR(E) 20-14	15.0	-	-	1069	1547	320	197	350	-	152	-	-	1069	1530	313	377	350	-	185.5
CR(E) 20-17	18.5	-	-	1204	1722	320	197	350	-	187	-	-	1204	1703	313	377	350	-	226.0

## CRI, CRN, CRIE, CRNE 20

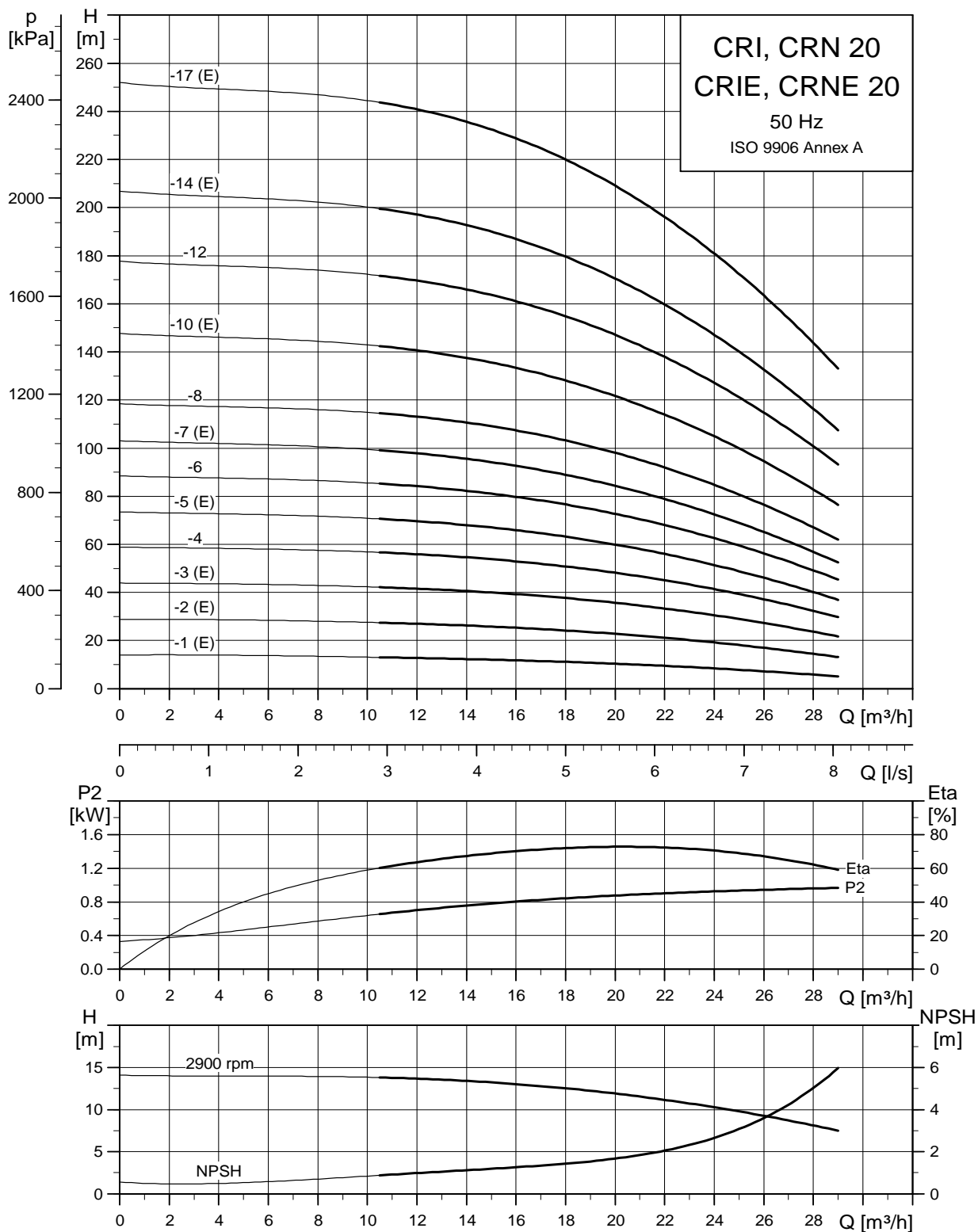

TM02 7301 3605



## Dimensional sketch

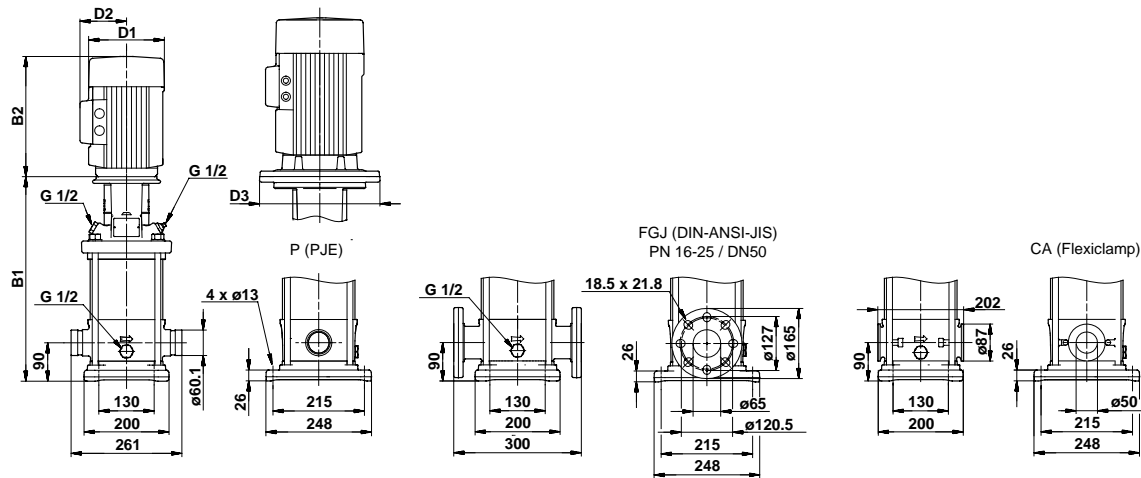

TM03 1728 2805

## Dimensions and weights

Pump type	Motor P <sub>2</sub> [kW]	CRI/CRN										CRIE/CRNE								
		Dimension [mm]									Net weight [kg]		Dimension [mm]						Net weight [kg]	
		PJE/CA		DIN flange		D1	D2	D3	PJE/CA	DIN flange	PJE/CA		DIN flange		D1	D2	D3	PJE/CA	DIN flange	
		B1	B1+B2	B1	B1+B2						B1	B1+B2	B1	B1+B2						
CRI(E)/CRN(E) 20-1	1.1	397	628	397	628	141	109	-	34	39	397	628	397	628	178	167	-	29.9	34.9	
CRI(E)/CRN(E) 20-2	2.2	413	734	413	734	178	110	-	42	47	413	734	413	734	178	167	-	52.5	57.5	
CRI(E)/CRN(E) 20-3	4.0	463	835	463	835	220	134	-	59	63	463	835	463	835	220	188	-	68.3	73.3	
CRI/CRN 20-4	5.5	540	931	540	931	220	134	300	80	85	-	-	-	-	-	-	-	-	-	
CRI(E)/CRN(E) 20-5	5.5	585	976	585	976	220	134	300	82	87	585	976	585	976	220	188	298	93.9	98.9	
CRI/CRN 20-6	7.5	630	1021	630	1021	220	134	300	85	90	-	-	-	-	-	-	-	-	-	
CRI(E)/CRN(E) 20-7	7.5	675	1066	675	1066	220	134	300	87	92	675	1066	675	1066	220	188	298	97.7	102.7	
CRI/CRN 20-8	11.0	797	1296	797	1296	260	172	350	119	123	-	-	-	-	-	-	-	-	-	
CRI(E)/CRN(E) 20-10	11.0	887	1386	887	1386	260	172	350	122	127	887	1336	887	1336	258	359	350	173.0	178.0	
CRI/CRN 20-12	15.0	977	1455	977	1455	320	197	350	140	145	-	-	-	-	-	-	-	-	-	
CRI(E)/CRN(E) 20-14	15.0	1067	1545	1067	1545	320	197	350	144	148	1067	1528	1067	1528	313	377	350	177.5	182.5	
CRI(E)/CRN(E) 20-17	18.5	1202	1720	1202	1720	320	197	350	179	183	1202	1701	1202	1701	313	377	350	218.0	222.0	

## CR, CRE 32

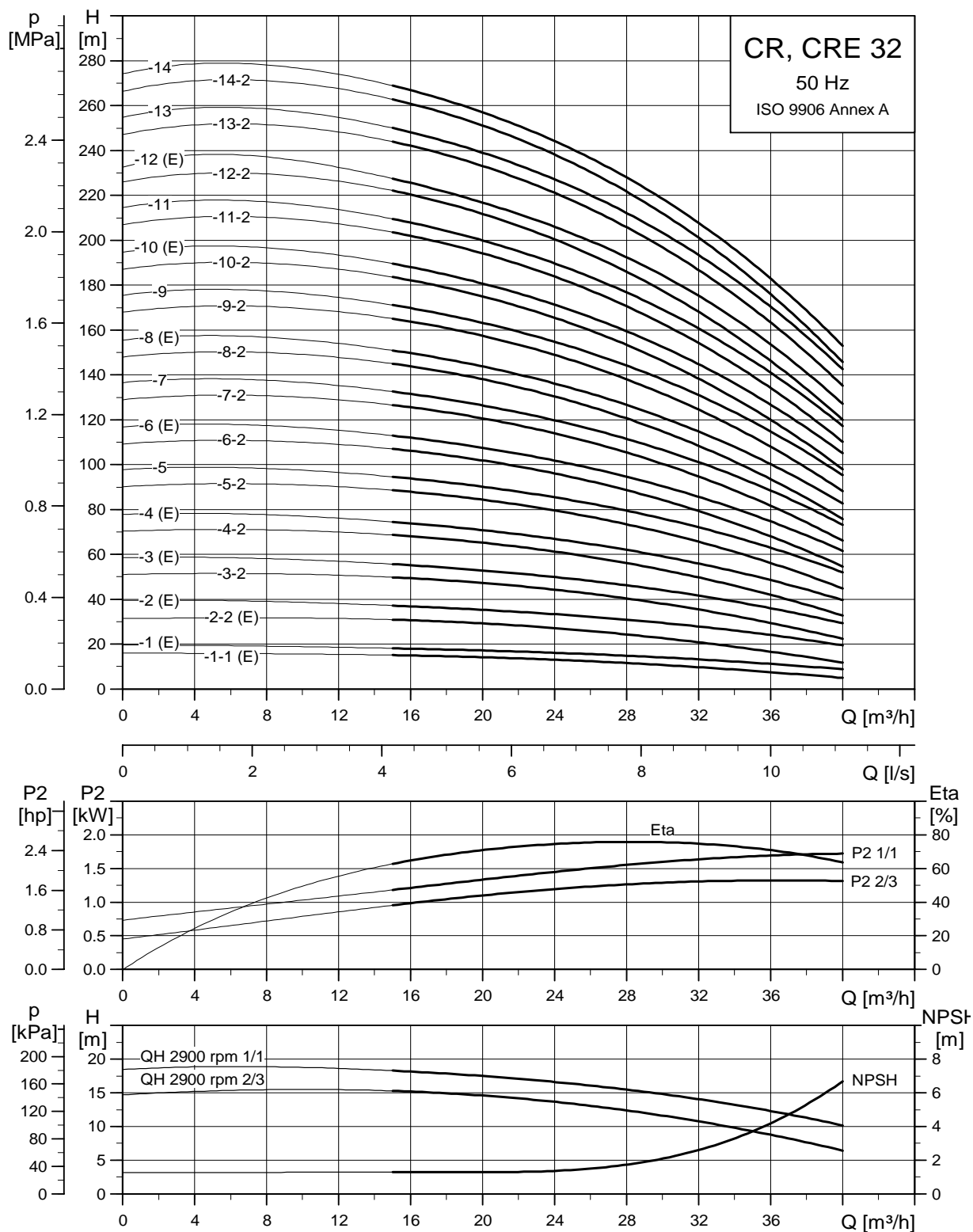

TM02 7302 3605

## Dimensional sketch

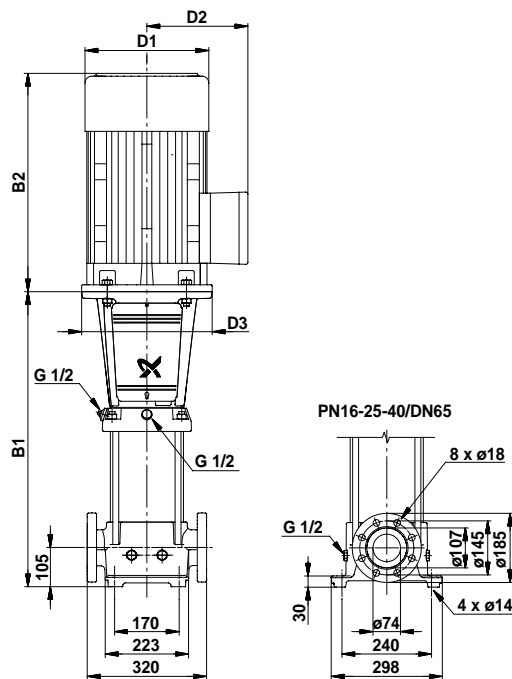

TM01 1749 3298

## Dimensions and weights

Pump type	Motor P <sub>2</sub> [kW]	CR					Net weight [kg]	CRE					Net weight [kg]
		Dimension [mm]						Dimension [mm]					
		DIN flange		D1	D2	D3		DIN flange		D1	D2	D3	
B1	B1+B2				B1	B1+B2							
CR(E) 32-1-1	1.5	505	786	178	110	135	61	505	786	178	167	135	78.5
CR(E) 32-1	2.2	505	826	178	110	135	62	505	826	178	167	135	89.5
CR(E) 32-2-2	3.0	575	910	198	120	-	76	575	910	198	177	145	98.0
CR(E) 32-2	4.0	575	947	220	134	158	87	575	947	220	188	160	109.3
CR 32-3-2	5.5	645	1036	220	134	298	107	-	-	-	-	-	-
CR(E) 32-3	5.5	645	1036	220	134	298	107	645	1036	220	188	298	119.9
CR 32-4-2	7.5	715	1106	220	134	298	117	-	-	-	-	-	-
CR(E) 32-4	7.5	715	1106	220	134	298	117	715	1106	220	188	298	126.7
CR 32-5-2	11.0	895	1394	260	172	350	155	-	-	-	-	-	-
CR 32-5	11.0	895	1394	260	172	350	155	-	-	-	-	-	-
CR 32-6-2	11.0	965	1464	260	172	350	158	-	-	-	-	-	-
CR(E) 32-6	11.0	965	1464	260	172	350	158	965	1414	258	359	350	212.0
CR 32-7-2	15.0	1035	1513	320	197	350	175	-	-	-	-	-	-
CR 32-7	15.0	1035	1513	320	197	350	175	-	-	-	-	-	-
CR 32-8-2	15.0	1105	1583	320	197	350	178	-	-	-	-	-	-
CR(E) 32-8	15.0	1105	1583	320	197	350	178	1105	1566	313	377	350	236.5
CR 32-9-2	18.5	1175	1693	320	197	350	211	-	-	-	-	-	-
CR 32-9	18.5	1175	1693	320	197	350	211	-	-	-	-	-	-
CR 32-10-2	18.5	1245	1763	320	197	350	214	-	-	-	-	-	-
CR(E) 32-10	18.5	1245	1763	320	197	350	214	1245	1744	313	377	350	280.0
CR 32-11-2	22.0	1315	1925	363	262	350	250	-	-	-	-	-	-
CR 32-11	22.0	1315	1925	363	262	350	250	-	-	-	-	-	-
CR 32-12-2	22.0	1385	1995	363	262	350	254	-	-	-	-	-	-
CR(E) 32-12	22.0	1385	1995	363	262	350	254	1385	1910	351	399	350	327.0
CR 32-13-2	30.0	1455	2101	415	300	400	322	-	-	-	-	-	-
CR 32-13	30.0	1455	2101	415	300	400	322	-	-	-	-	-	-
CR 32-14-2	30.0	1525	2171	415	300	400	325	-	-	-	-	-	-
CR 32-14	30.0	1525	2171	415	300	400	325	-	-	-	-	-	-

## CRN, CRNE 32

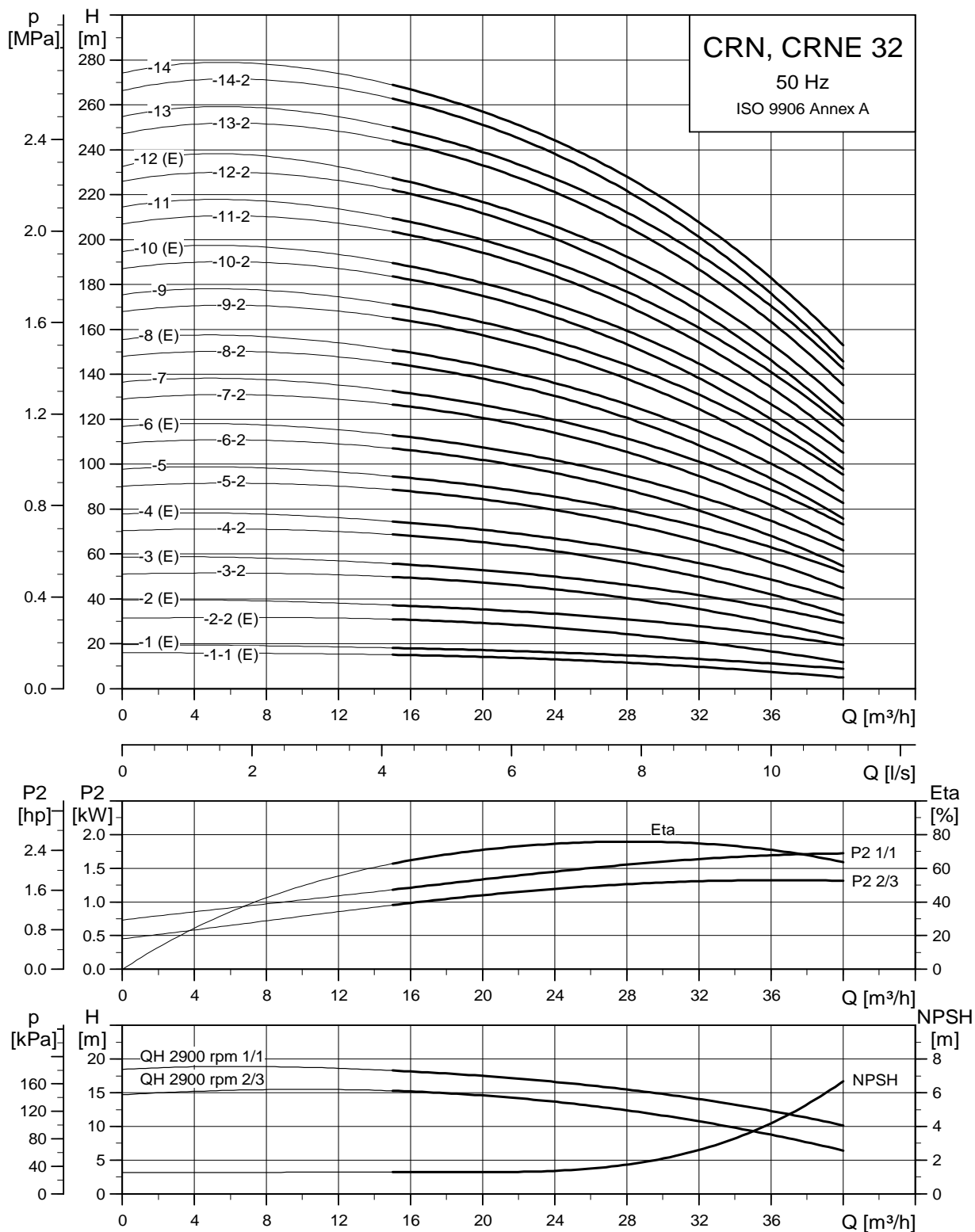

TM02 7303 3605

## Dimensional sketch

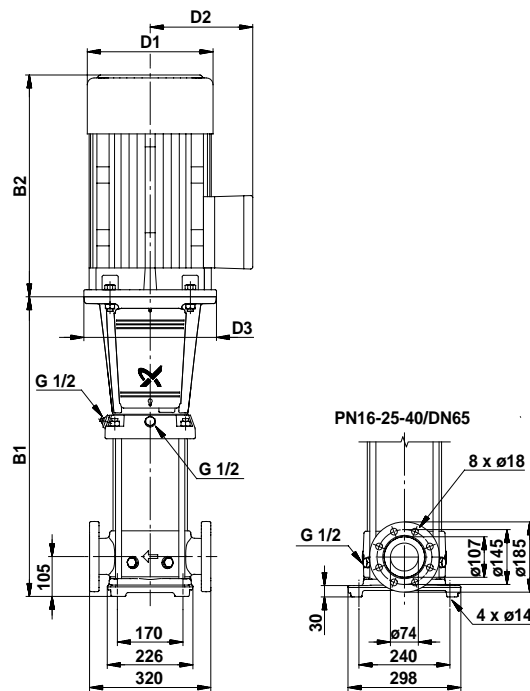

TM01 1750 2203

## Dimensions and weights

Pump type	Motor P <sub>2</sub> [kW]	CRN						CRNE					
		Dimension [mm]					Net weight [kg]	Dimension [mm]					Net weight [kg]
		DIN flange		D1	D2	D3		DIN flange		D1	D2	D3	
B1	B1+B2					B1	B1+B2						
CRN(E) 32-1-1	1.5	505	786	178	110	135	61	505	786	178	167	135	78.5
CRN(E) 32-1	2.2	505	826	178	110	135	62	505	826	178	167	135	89.5
CRN(E) 32-2-2	3.0	575	910	198	120	-	76	575	910	198	177	145	97.0
CRN(E) 32-2	4.0	575	947	220	134	158	87	575	947	220	188	160	108.3
CRN 32-3-2	5.5	645	1036	220	134	298	107	-	-	-	-	-	-
CRN(E) 32-3	5.5	645	1036	220	134	298	107	645	1036	220	188	298	118.9
CRN 32-4-2	7.5	715	1106	220	134	298	117	-	-	-	-	-	-
CRN(E) 32-4	7.5	715	1106	220	134	298	117	715	1106	220	188	298	126.7
CRN 32-5-2	11.0	895	1394	260	172	350	155	-	-	-	-	-	-
CRN 32-5	11.0	895	1394	260	172	350	155	-	-	-	-	-	-
CRN 32-6-2	11.0	965	1464	260	172	350	158	-	-	-	-	-	-
CRN(E) 32-6	11.0	965	1464	260	172	350	158	965	1414	258	359	350	212.0
CRN 32-7-2	15.0	1035	1513	320	197	350	175	-	-	-	-	-	-
CRN 32-7	15.0	1035	1513	320	197	350	175	-	-	-	-	-	-
CRN 32-8-2	15.0	1105	1583	320	197	350	178	-	-	-	-	-	-
CRN(E) 32-8	15.0	1105	1583	320	197	350	178	1105	1566	313	377	350	236.5
CRN 32-9-2	18.5	1175	1693	320	197	350	211	-	-	-	-	-	-
CRN 32-9	18.5	1175	1693	320	197	350	211	-	-	-	-	-	-
CRN 32-10-2	18.5	1245	1763	320	197	350	214	-	-	-	-	-	-
CRN(E) 32-10	18.5	1245	1763	320	197	350	214	1245	1744	313	377	350	279.0
CRN 32-11-2	22.0	1315	1925	363	262	350	250	-	-	-	-	-	-
CRN 32-11	22.0	1315	1925	363	262	350	250	-	-	-	-	-	-
CRN 32-12-2	22.0	1385	1995	363	262	350	254	-	-	-	-	-	-
CRN(E) 32-12	22.0	1385	1995	363	262	350	254	1385	1910	351	399	350	326.0
CRN 32-13-2	30.0	1455	2101	415	300	400	322	-	-	-	-	-	-
CRN 32-13	30.0	1455	2101	415	300	400	322	-	-	-	-	-	-
CRN 32-14-2	30.0	1525	2171	415	300	400	325	-	-	-	-	-	-
CRN 32-14	30.0	1525	2171	415	300	400	325	-	-	-	-	-	-

## CR, CRE 45

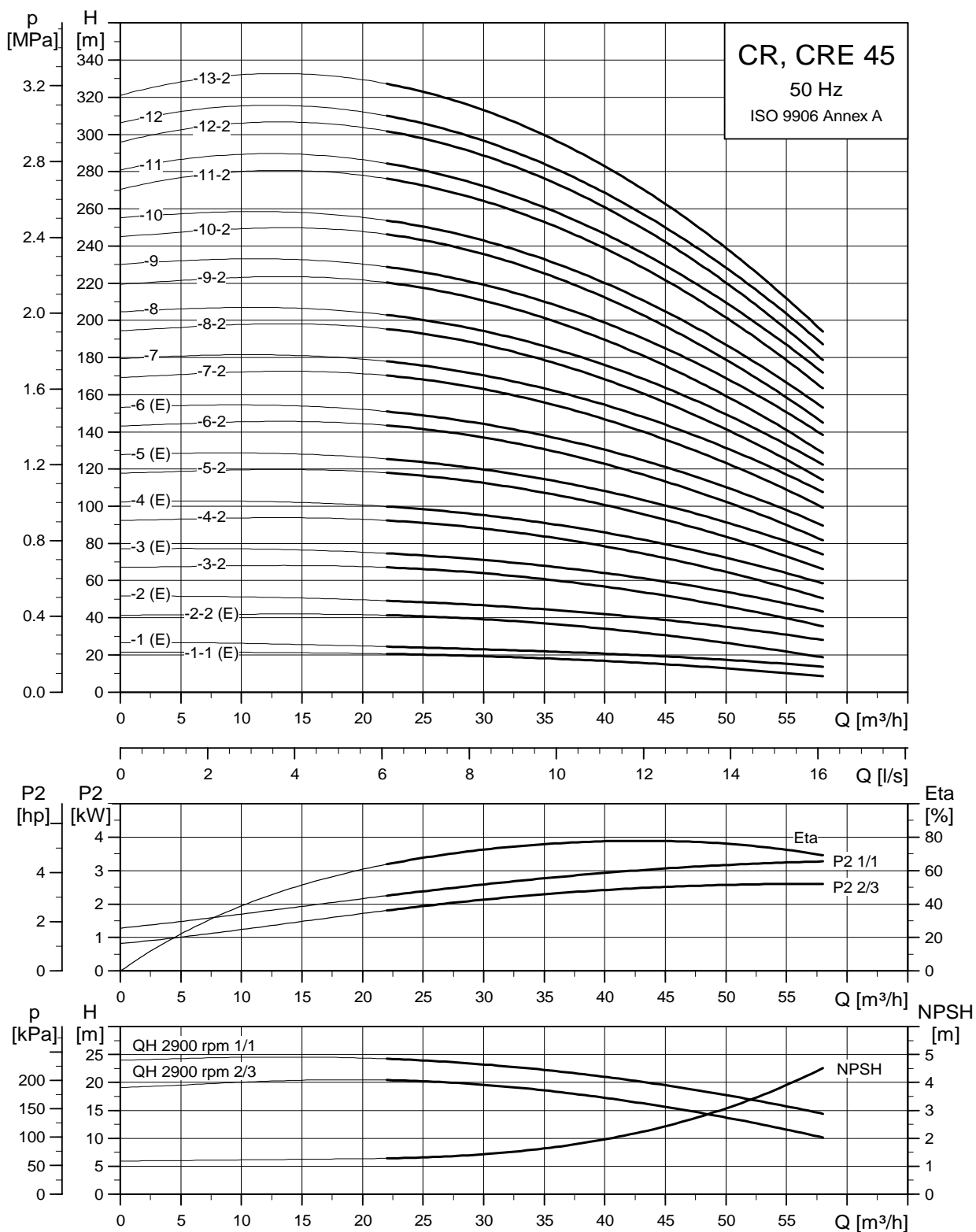

TM02 7304 3605

## Dimensional sketch

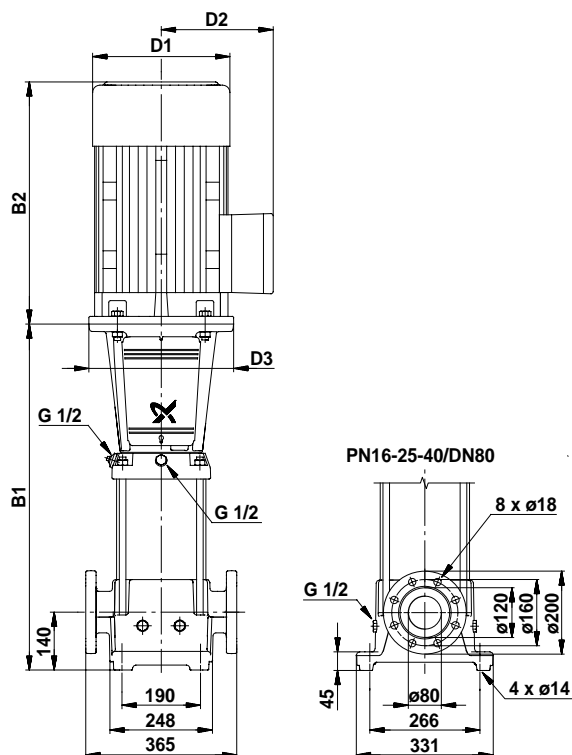

TM01 1751 3203

## Dimensions and weights

Pump type	Motor P <sub>2</sub> [kW]	CR						CRE					
		Dimension [mm]					Net weight [kg]	Dimension [mm]					Net weight [kg]
		DIN flange		D1	D2	D3		DIN flange		D1	D2	D3	
B1	B1+B2				B1	B1+B2							
CR(E) 45-1-1	3.0	559	894	198	120	-	80	559	894	198	177	145	104.0
CR(E) 45-1	4.0	559	931	220	134	158	91	559	931	220	188	160	115.3
CR(E) 45-2-2	5.5	639	1030	220	134	298	108	639	1030	220	188	298	125.9
CR(E) 45-2	7.5	639	1030	220	134	298	110	639	1030	220	188	298	129.7
CR 45-3-2	11.0	829	1328	260	172	350	149	-	-	-	-	-	-
CR(E) 45-3	11.0	829	1328	260	172	350	149	829	1278	258	359	350	211.0
CR 45-4-2	15.0	909	1387	320	197	350	169	-	-	-	-	-	-
CR(E) 45-4	15.0	909	1387	320	197	350	169	909	1370	313	377	350	231.5
CR 45-5-2	18.5	989	1507	320	197	350	204	-	-	-	-	-	-
CR(E) 45-5	18.5	989	1507	320	197	350	204	989	1488	313	377	350	271.0
CR 45-6-2	22.0	1069	1679	363	262	350	240	-	-	-	-	-	-
CR(E) 45-6	22.0	1069	1679	363	262	350	240	1069	1594	351	399	350	314.0
CR 45-7-2	30.0	1149	1795	415	300	400	321	-	-	-	-	-	-
CR 45-7	30.0	1149	1795	415	300	400	321	-	-	-	-	-	-
CR 45-8-2	30.0	1229	1875	415	300	400	336	-	-	-	-	-	-
CR 45-8	30.0	1229	1875	415	300	400	336	-	-	-	-	-	-
CR 45-9-2	30.0	1309	1955	415	300	400	341	-	-	-	-	-	-
CR 45-9	37.0	1309	2012	415	300	400	361	-	-	-	-	-	-
CR 45-10-2	37.0	1389	2092	415	300	400	366	-	-	-	-	-	-
CR 45-10	37.0	1389	2092	415	300	400	366	-	-	-	-	-	-
CR 45-11-2	45.0	1469	2178	442	325	450	478	-	-	-	-	-	-
CR 45-11	45.0	1469	2178	442	325	450	478	-	-	-	-	-	-
CR 45-12-2	45.0	1549	2258	442	325	450	483	-	-	-	-	-	-
CR 45-12	45.0	1549	2258	442	325	450	483	-	-	-	-	-	-
CR 45-13-2	45.0	1629	2338	442	325	450	488	-	-	-	-	-	-

## CRN, CRNE 45

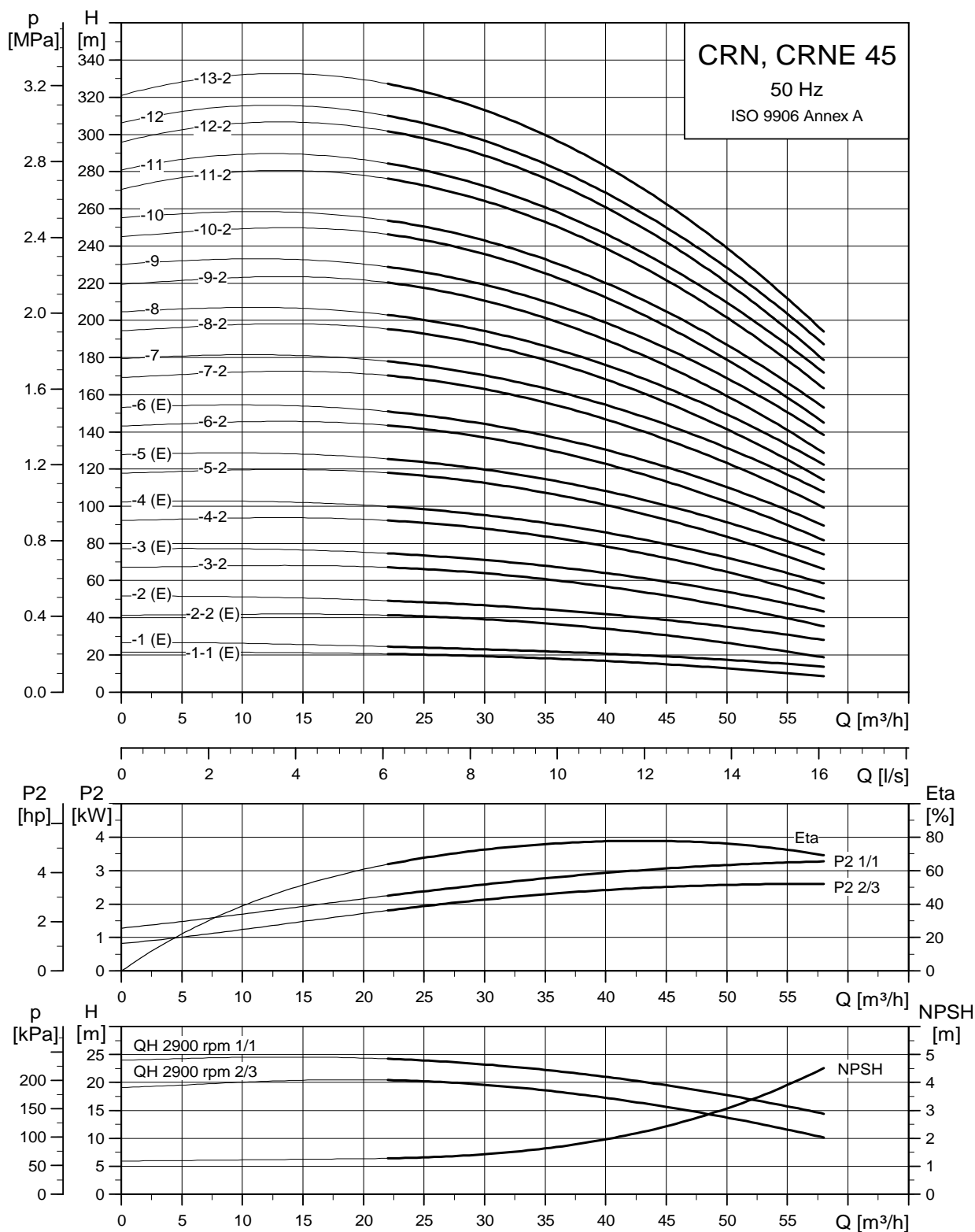

TM02 7305 3605



## Dimensional sketch

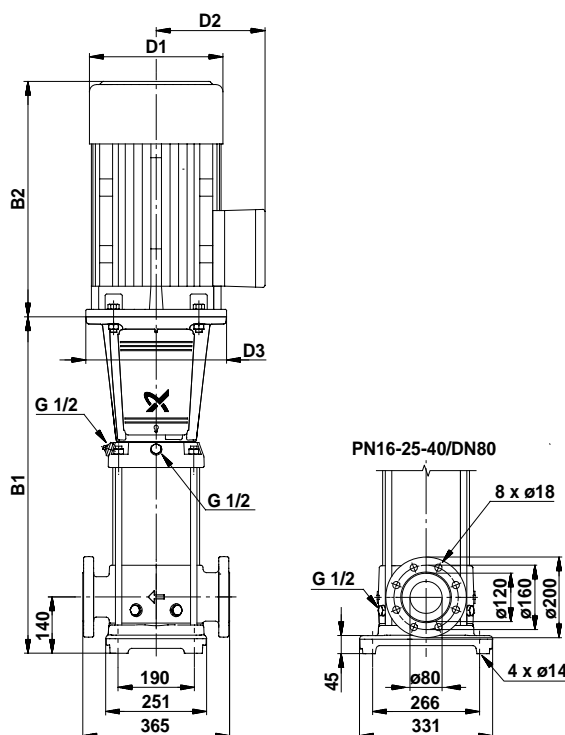

TM01 1752 3203

## Dimensions and weights

Pump type	Motor P <sub>2</sub> [kW]	CRN						CRNE					
		Dimension [mm]					Net weight [kg]	Dimension [mm]					Net weight [kg]
		DIN flange		D1	D2	D3		DIN flange		D1	D2	D3	
B1	B1+B2					B1	B1+B2						
CRN(E) 45-1-1	3.0	559	894	198	120	-	80	559	894	198	177	145	103.0
CRN(E) 45-1	4.0	559	931	220	134	158	91	559	931	220	188	160	114.3
CRN(E) 45-2-2	5.5	639	1030	220	134	298	108	639	1030	220	188	298	124.9
CRN(E) 45-2	7.5	639	1030	220	148	300	110	639	1030	220	188	298	128.7
CRN 45-3-2	11.0	829	1328	260	172	350	149	-	-	-	-	-	-
CRN(E) 45-3	11.0	829	1328	260	172	350	149	829	1278	258	359	350	210.0
CRN 45-4-2	15.0	909	1387	320	197	350	169	-	-	-	-	-	-
CRN(E) 45-4	15.0	909	1387	320	197	350	169	909	1370	313	377	350	231.5
CRN 45-5-2	18.5	989	1507	320	197	350	204	-	-	-	-	-	-
CRN(E) 45-5	18.5	989	1507	320	197	350	204	989	1488	313	377	350	270.0
CRN 45-6-2	22.0	1069	1679	363	262	350	240	-	-	-	-	-	-
CRN(E) 45-6	22.0	1069	1679	363	262	350	240	1069	1594	351	399	350	313.0
CRN 45-7-2	30.0	1149	1795	415	300	400	321	-	-	-	-	-	-
CRN 45-7	30.0	1149	1795	415	300	400	321	-	-	-	-	-	-
CRN 45-8-2	30.0	1229	1875	415	300	400	336	-	-	-	-	-	-
CRN 45-8	30.0	1229	1875	415	300	400	336	-	-	-	-	-	-
CRN 45-9-2	30.0	1309	1955	415	300	400	341	-	-	-	-	-	-
CRN 45-9	37.0	1309	2012	415	300	400	361	-	-	-	-	-	-
CRN 45-10-2	37.0	1389	2092	415	300	400	366	-	-	-	-	-	-
CRN 45-10	37.0	1389	2092	415	300	400	366	-	-	-	-	-	-
CRN 45-11-2	45.0	1469	2178	442	325	450	478	-	-	-	-	-	-
CRN 45-11	45.0	1469	2178	442	325	450	478	-	-	-	-	-	-
CRN 45-12-2	45.0	1549	2258	442	325	450	483	-	-	-	-	-	-
CRN 45-12	45.0	1549	2258	442	325	450	483	-	-	-	-	-	-
CRN 45-13-2	45.0	1629	2338	442	325	450	488	-	-	-	-	-	-

## CR, CRE 64

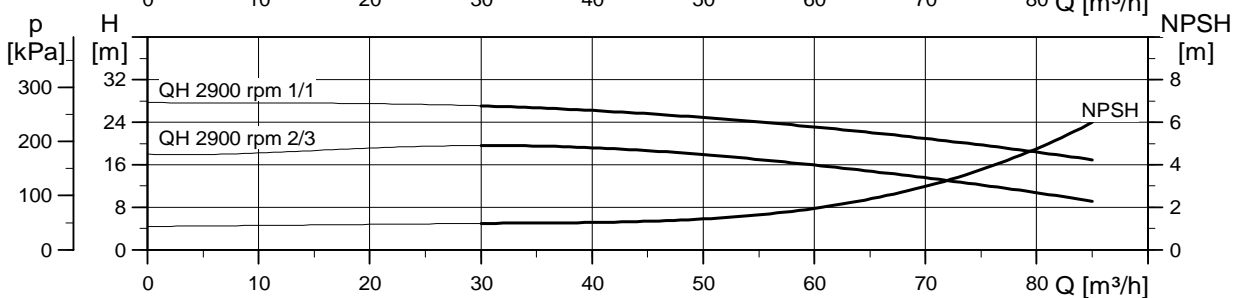
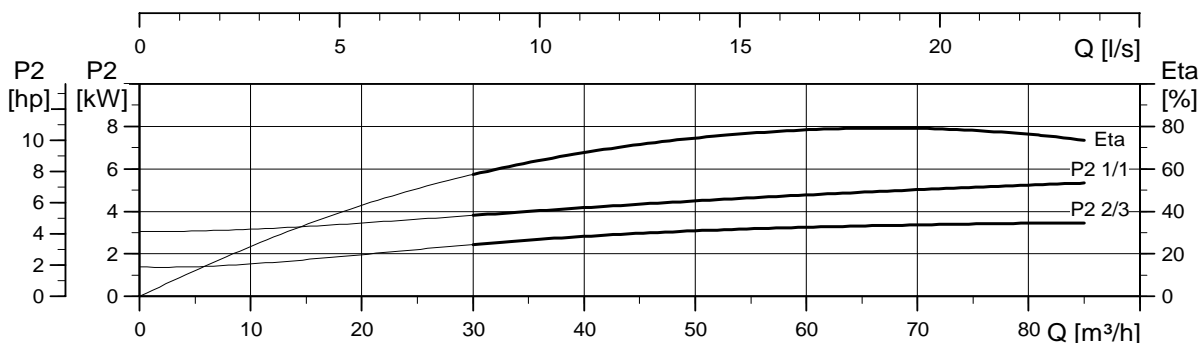
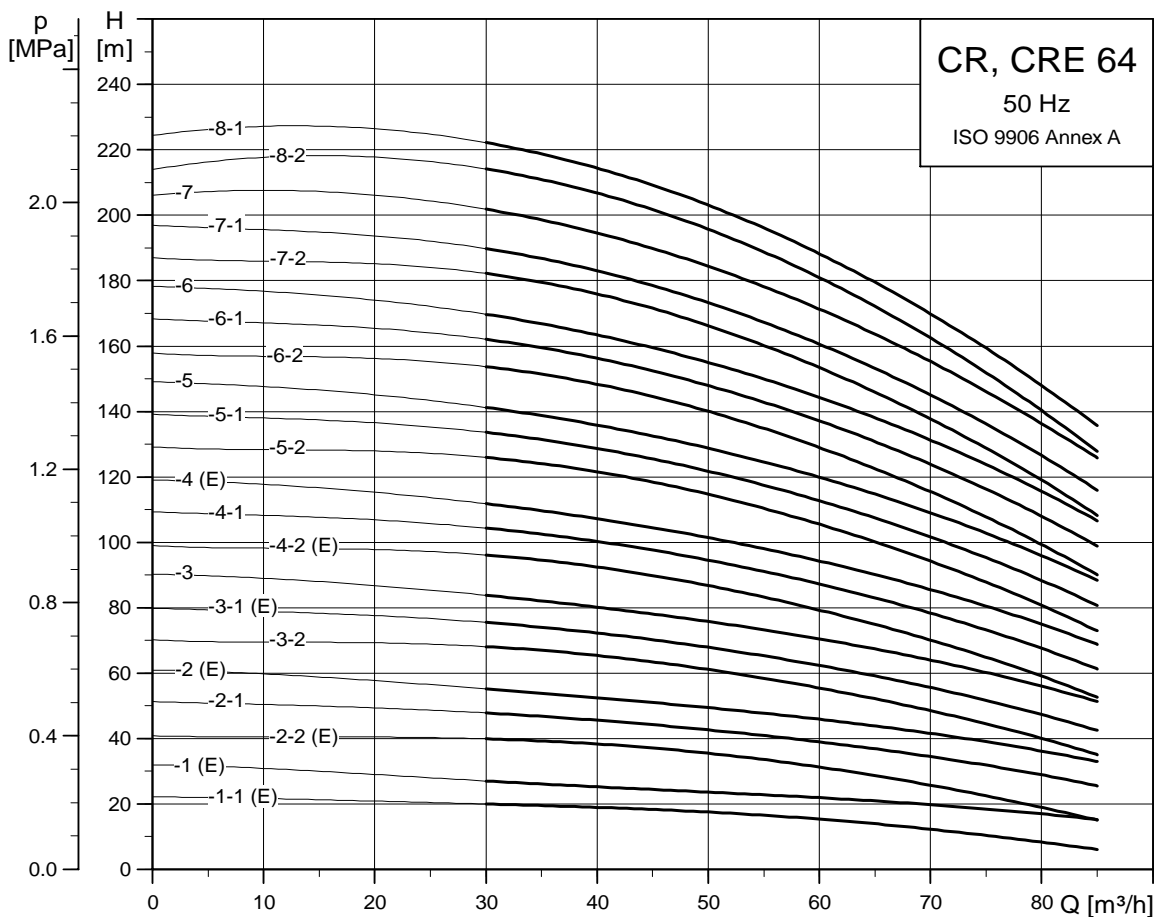

TM02 7306 3605

## Dimensional sketch

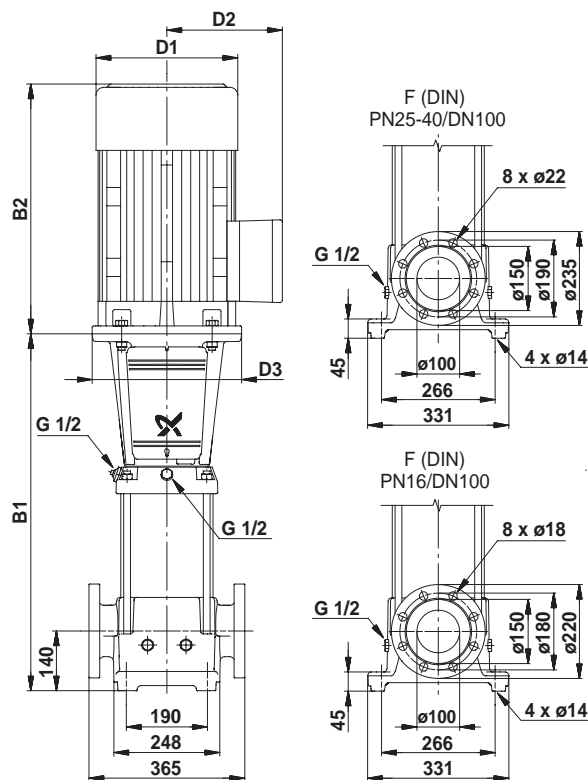

TM01 1753 5197

## Dimensions and weights

Pump type	Motor P <sub>2</sub> [kW]	CR						CRE					
		Dimension [mm]					Net weight [kg]	Dimension [mm]					Net weight [kg]
		DIN flange		D1	D2	D3		DIN flange		D1	D2	D3	
B1	B1+B2				B1	B1+B2							
CR(E) 64-1-1	4.0	561	933	220	134	158	91	561	933	220	188	160	118.3
CR(E) 64-1	5.5	561	952	220	134	298	102	561	952	220	188	298	124.9
CR(E) 64-2-2	7.5	644	1035	220	134	298	114	644	1035	220	188	298	132.7
CR 64-2-1	11.0	754	1253	260	172	350	149	-	-	-	-	-	-
CR(E) 64-2	11.0	754	1253	260	172	350	149	754	1203	258	359	350	210.0
CR 64-3-2	15.0	836	1314	320	197	350	174	-	-	-	-	-	-
CR(E) 64-3-1	15.0	836	1314	320	197	350	174	836	1297	313	377	350	231.5
CR 64-3	18.5	836	1354	320	197	350	204	-	-	-	-	-	-
CR(E) 64-4-2	18.5	919	1437	320	197	350	214	919	1418	313	377	350	270.0
CR 64-4-1	22.0	919	1529	363	262	350	245	-	-	-	-	-	-
CR(E) 64-4	22.0	919	1529	363	262	350	245	919	1444	351	399	350	309.0
CR 64-5-2	30.0	1001	1647	415	300	400	316	-	-	-	-	-	-
CR 64-5-1	30.0	1001	1647	415	300	400	316	-	-	-	-	-	-
CR 64-5	30.0	1001	1647	415	300	400	316	-	-	-	-	-	-
CR 64-6-2	30.0	1084	1730	415	300	400	336	-	-	-	-	-	-
CR 64-6-1	37.0	1084	1787	415	300	400	356	-	-	-	-	-	-
CR 64-6	37.0	1084	1787	415	300	400	356	-	-	-	-	-	-
CR 64-7-2	37.0	1166	1869	415	300	400	376	-	-	-	-	-	-
CR 64-7-1	37.0	1166	1869	415	300	400	376	-	-	-	-	-	-
CR 64-7	45.0	1166	1875	442	325	450	440	-	-	-	-	-	-
CR 64-8-2	45.0	1249	1958	442	325	450	473	-	-	-	-	-	-
CR 64-8-1	45.0	1249	1958	442	325	450	473	-	-	-	-	-	-

## CRN, CRNE 64

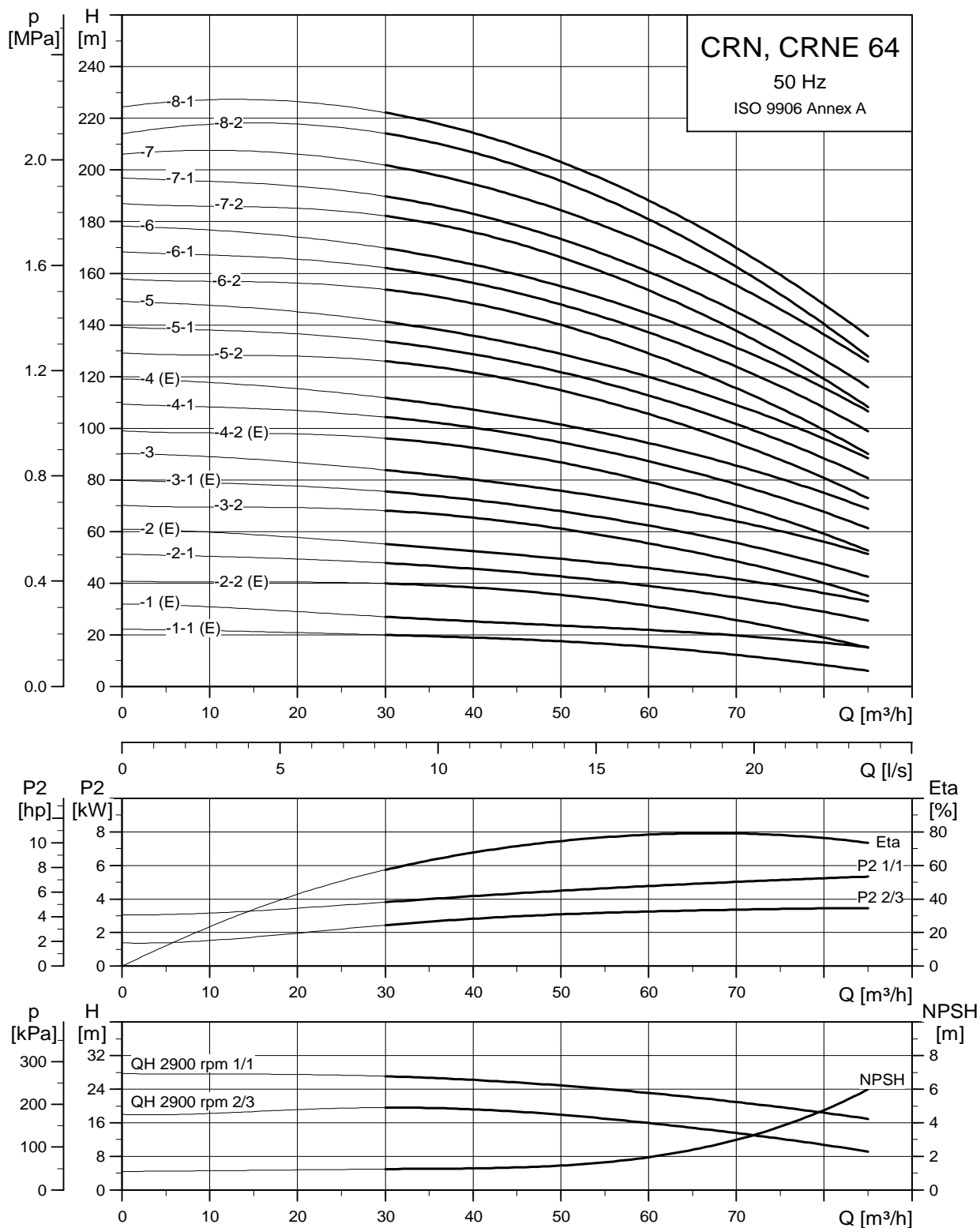

TM02 7307 3605

## Dimensional sketch

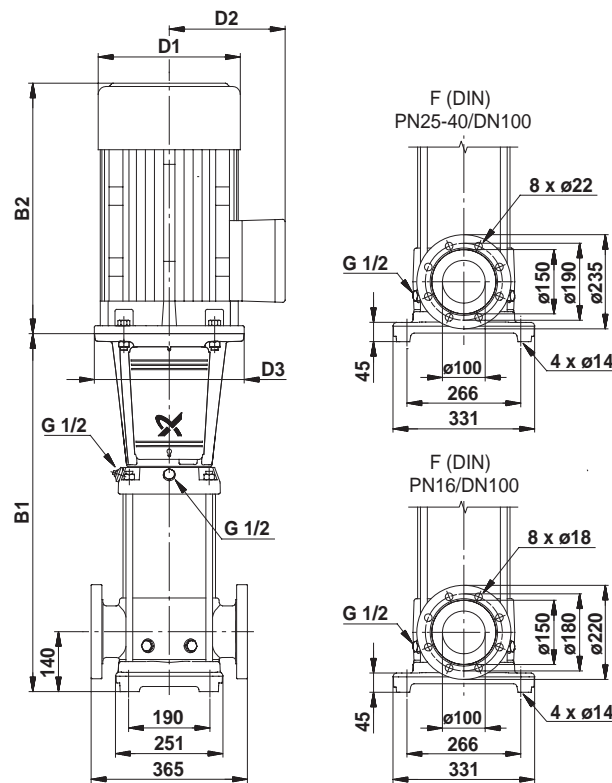

TM01 1754 0904

## Dimensions and weights

Pump type	Motor P <sub>2</sub> [kW]	CRN						CRNE					
		Dimension [mm]					Net weight [kg]	Dimension [mm]					Net weight [kg]
		DIN flange		D1	D2	D3		DIN flange		D1	D2	D3	
B1	B1+B2					B1	B1+B2						
CRN(E) 64-1-1	4.0	561	933	220	134	158	91	561	933	220	188	160	117.3
CRN(E) 64-1	5.5	561	952	220	134	298	102	561	952	220	188	298	123.9
CRN(E) 64-2-2	7.5	644	1035	220	134	298	114	644	1035	220	188	298	131.7
CRN 64-2-1	11.0	754	1253	260	172	350	149	-	-	-	-	-	-
CRN(E) 64-2	11.0	754	1253	260	172	350	149	754	1203	258	359	350	209.0
CRN 64-3-2	15.0	836	1314	320	197	350	174	-	-	-	-	-	-
CRN(E) 64-3-1	15.0	836	1314	320	197	350	174	836	1297	313	377	350	229.5
CRN 64-3	18.5	836	1354	320	197	350	204	-	-	-	-	-	-
CRN(E) 64-4-2	18.5	919	1437	320	197	350	214	919	1418	313	377	350	269.0
CRN 64-4-1	22.0	919	1529	363	262	350	245	-	-	-	-	-	-
CRN(E) 64-4	22.0	919	1529	363	262	350	245	919	1444	351	399	350	308.0
CRN 64-5-2	30.0	1001	1647	415	300	400	316	-	-	-	-	-	-
CRN 64-5-1	30.0	1001	1647	415	300	400	316	-	-	-	-	-	-
CRN 64-5	30.0	1001	1647	415	300	400	316	-	-	-	-	-	-
CRN 64-6-2	30.0	1084	1730	415	300	400	336	-	-	-	-	-	-
CRN 64-6-1	37.0	1084	1787	415	300	400	356	-	-	-	-	-	-
CRN 64-6	37.0	1084	1787	415	300	400	356	-	-	-	-	-	-
CRN 64-7-2	37.0	1166	1869	415	300	400	376	-	-	-	-	-	-
CRN 64-7-1	37.0	1166	1869	415	300	400	376	-	-	-	-	-	-
CRN 64-7	45.0	1166	1875	442	325	450	440	-	-	-	-	-	-
CRN 64-8-2	45.0	1249	1958	442	325	450	473	-	-	-	-	-	-
CRN 64-8-1	45.0	1249	1958	442	325	450	473	-	-	-	-	-	-

## CR, CRE 90

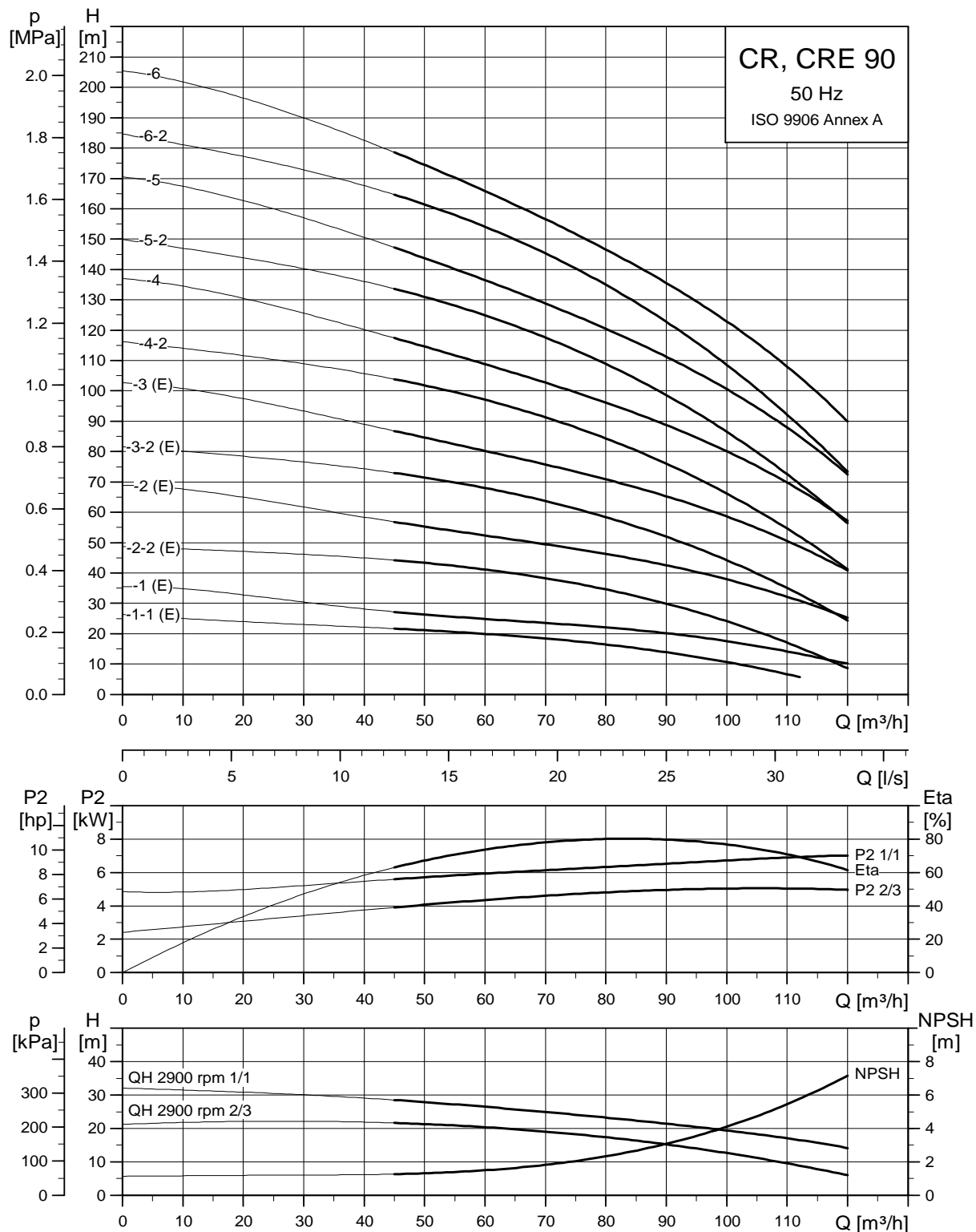

TM02 7308 3605

## Dimensional sketch

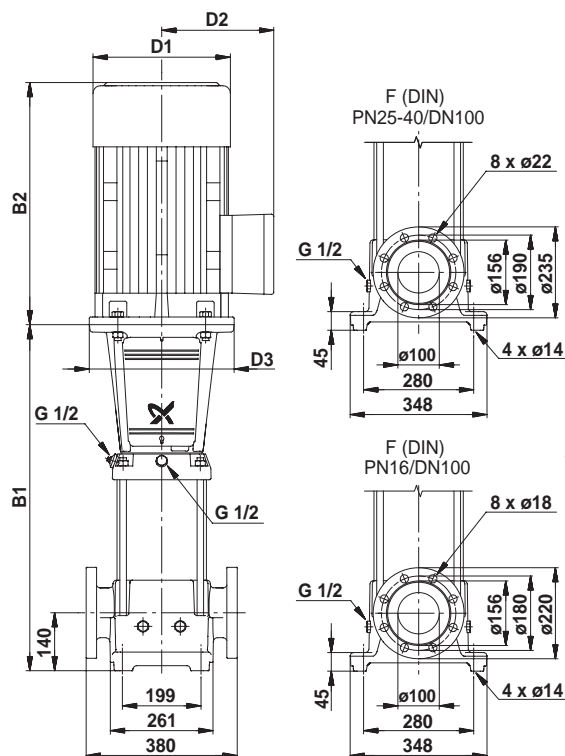

TM01 1755 2203

## Dimensions and weights

Pump type	Motor P <sub>2</sub> [kW]	CR						CRE					
		Dimension [mm]					Net weight [kg]	Dimension [mm]					Net weight [kg]
		DIN flange		D1	D2	D3		DIN flange		D1	D2	D3	
B1	B1+B2					B1	B1+B2						
CR(E) 90-1-1	5.5	571	962	220	134	298	107	571	962	220	188	298	130.9
CR(E) 90-1	7.5	571	962	220	134	298	109	571	962	220	188	298	133.7
CR(E) 90-2-2	11.0	773	1272	260	172	350	150	773	1222	258	359	350	216.0
CR(E) 90-2	15.0	773	1251	320	197	350	164	773	1234	313	377	350	232.5
CR(E) 90-3-2	18.5	865	1383	320	197	350	214	865	1364	313	377	350	272.0
CR(E) 90-3	22.0	865	1475	363	262	350	245	865	1390	351	399	350	311.0
CR 90-4-2	30.0	957	1603	415	300	400	326	-	-	-	-	-	-
CR 90-4	30.0	957	1603	415	300	400	326	-	-	-	-	-	-
CR 90-5-2	37.0	1049	1752	415	300	400	366	-	-	-	-	-	-
CR 90-5	37.0	1049	1752	415	300	400	366	-	-	-	-	-	-
CR 90-6-2	45.0	1141	1850	442	325	450	437	-	-	-	-	-	-
CR 90-6	45.0	1141	1850	442	325	450	437	-	-	-	-	-	-

## CRN, CRNE 90

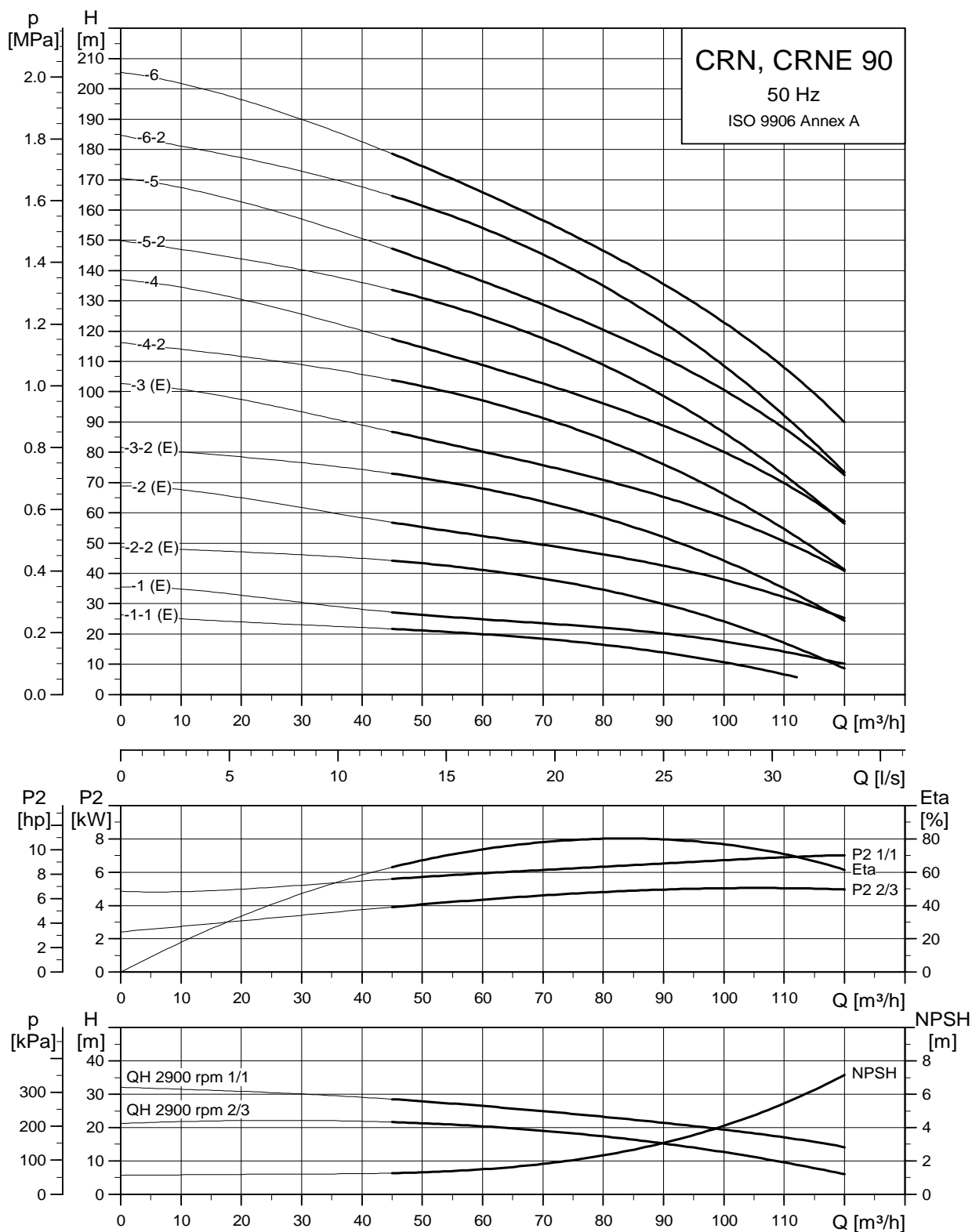

TM02 7309 3605



## Dimensional sketch

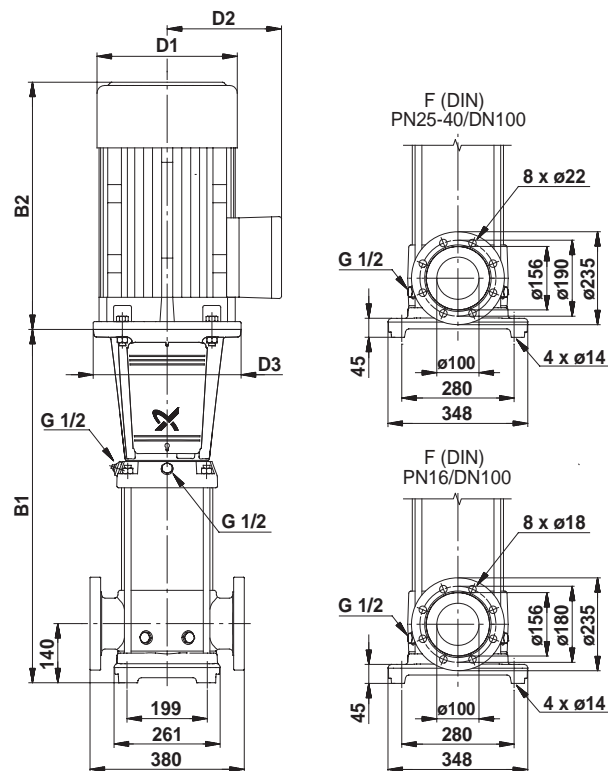

TM02 1570 2203

## Dimensions and weights

Pump type	Motor P <sub>2</sub> [kW]	CRN						CRNE					
		Dimension [mm]					Net weight [kg]	Dimension [mm]					Net weight [kg]
		DIN flange		D1	D2	D3		DIN flange		D1	D2	D3	
B1	B1+B2				B1	B1+B2							
CRN(E) 90-1-1	5.5	571	962	220	134	298	107	571	962	220	188	298	130.9
CRN(E) 90-1	7.5	571	962	220	134	298	109	571	962	220	188	298	133.7
CRN(E) 90-2-2	11.0	773	1272	260	172	350	150	773	1222	258	359	350	216.0
CRN(E) 90-2	15.0	773	1251	320	197	350	164	773	1234	313	377	350	232.5
CRN(E) 90-3-2	18.5	865	1383	320	197	350	214	865	1364	313	377	350	272.0
CRN(E) 90-3	22.0	865	1475	363	262	350	245	865	1390	351	399	350	311.0
CRN 90-4-2	30.0	957	1603	415	300	400	326	-	-	-	-	-	-
CRN 90-4	30.0	957	1603	415	300	400	326	-	-	-	-	-	-
CRN 90-5-2	37.0	1049	1752	415	300	400	366	-	-	-	-	-	-
CRN 90-5	37.0	1049	1752	415	300	400	366	-	-	-	-	-	-
CRN 90-6-2	45.0	1141	1850	442	325	450	437	-	-	-	-	-	-
CRN 90-6	45.0	1141	1850	442	325	450	437	-	-	-	-	-	-

## Standard motors for CR, CRI, CRN, 50 Hz

Motor P <sub>2</sub> [kW]	Frame size	Standard voltage [V]	I <sub>1/1</sub> [A]	Cos φ <sub>1/1</sub>	η [%]	$\frac{I_{start}}{I_{1/1}}$
0.37	71	220-240Δ/380-415Y	1.7/1	0.8-0.7	78.5	8.5-9.2/4.9-5.3
0.55	71	220-240Δ/380-415Y	2.5/1.4	0.8-0.7	80	12-13/6.9-7.5
0.75	80	220-240Δ/380-415Y	3.3/1.9	0.81-0.71	81	19.1-20.5/11.0-11.8
1.1	80	220-240Δ/380-415Y	4.5/2.6	0.84-0.76	82.8	28.5-31.5/16.3-17.9
1.5	90	220-240Δ/380-415Y	5.5/3.2	0.87-0.82	85.5	46.3-50.7/26.8-29.3
2.2	90	380-415Δ	4.5-4.5	0.89-0.87	87.5	37.8-42.3
3.0	100	220-240Δ/380-415Y	11-6.4	0.87-0.8	85	88-96.8/50.8-55.7
4.0	112	380-415Δ	8-8	0.88-0.84	89	89.6-98.4
5.5	132	380-415Δ	11.2-11.2	0.88-0.84	90	119.8-131.0
7.5	132	380-415Δ	15.2-15.2	0.87-0.8	89.5	152-168.7
11	160	380-415Δ	21.4-21.4	0.9-0.9	91.4	156.2-171.2

MG



TM03 1711 2805



15	160	380-415Δ/660-690Y	26.5/15.2	0.9-0.9	91.5	185.5/106.4
18.5	160	380-415Δ/660-690Y	31.5/18.4	0.92-0.92	92.5	220.5/128.8
22	180	380-415Δ/660-690Y	38.5/22	0.88-0.88	94	277.2/158.4
30	200	380-415Δ/660-690Y	53/30.5	0.88-0.88	93.5	371/213.5
37	200	380-415Δ/660-690Y	64/37	0.89-0.89	94	460.8/266.4
45	225	380-415Δ/660-690Y	77/44.5	0.89-0.89	95	562.1/324.9

Siemens



TM03 1710 2805

## E-motors for CRE, CRIE, CRNE, 50 Hz

Motor P <sub>2</sub> [kW]	Frame size	Phase	Standard voltage [V]	I <sub>1/1</sub> [A]	cos φ <sub>1/1</sub>	η [%]	
0.37	71	1	200-240	2.7-2.5	0.96	68	 <p>MGE</p> <p>TM03 1712 2805</p>
0.55	71	1	200-240	3.9-3.6	0.96	70	
0.75	80	1	200-240	5.1-4.7	0.97	72	
1.1	80	1	200-240	7.4-6.8	0.97	73	
1.5	90	3	380-480	4	0.74	78	
2.2	90	3	380-480	5.35	0.77	80	
3.0	100	3	380-480	6.8	0.83	81	
4.0	112	3	380-480	9	0.84	82	
5.5	132	3	380-480	12	0.86	82	
7.5	132	3	380-480	16	0.86	84.5	
11	160	3	380-415	21.4	0.93	84	 <p>MMGE</p> <p>TM03 1713 2805</p>
15	160	3	380-415	28	0.94	85.5	
18.5	160	3	380-415	34	0.95	85.5	
22	180	3	380-415	42	0.94	85	

## Pumped liquids

Thin, non-explosive liquids, not containing solid particles or fibres. The liquid must not chemically attack the pump materials.

When pumping liquids with a density and/or viscosity higher than that of water, oversized motors must be used, if required.

Whether a pump is suitable for a particular liquid depends on a number of factors of which the most important are the chloride content, pH value, temperature and content of chemicals, oils, etc.

Please note that aggressive liquids (e.g. sea water and some acids) may attack or dissolve the protective oxide film of the stainless steel and thus cause corrosion.

The CR(E), CRI(E), CRN(E) pump types are suitable for the following liquids:

### CR(E), CRI(E)

- Non-corrosive liquids.

For liquid transfer, circulation and pressure boosting of cold or hot clean water.

### CRN(E)

- Industrial liquids.

In systems where all parts in contact with the liquid must be made of high-grade stainless steel.

### CRT(E)

- Saline liquids.
- Hypochlorites.
- Acids.

For saline or chloride-containing liquids such as sea water or oxidizing agents such as hypochlorites, CRT(E) pumps of titanium are available. See separate data booklet on CRT(E).

## List of pumped liquids

A number of typical liquids are listed below.

Other pump versions may be applicable, but those stated in the list are considered to be the best choices.

The table is intended as a general guide only, and cannot replace actual testing of the pumped liquids and pump materials under specific working conditions.

The list should, however, be applied with some caution as factors such as

- concentration of the pumped liquid,
- liquid temperature or
- pressure.

may affect the chemical resistance of a specific pump version.

Safety precautions must be made when pumping dangerous liquids.

### Notes

<b>D</b>	Often with additives.
<b>E</b>	Density and/or viscosity differ from that of water. Allow for this when calculating motor output and pump performance.
<b>F</b>	Pump selection depends on many factors. Contact Grundfos.
<b>H</b>	Risk of chrySTALLIZATION/precipitation in shaft seal.
<b>1</b>	The pumped liquid highly inflammable.
<b>2</b>	The pumped liquid is combustible.
<b>3</b>	Insoluble in water.
<b>4</b>	Low self-ignition point.

Pumped liquid	Note	Liquid concentration, liquid temperature	CR(E), CRI(E)			CRN(E)		
			1s, 1, 3, 5	10, 15, 20	32, 45, 64, 90	1s, 1, 3, 5	10, 15, 20	32, 45, 64, 90
Acetic acid, CH <sub>3</sub> COOH	-	5%, +20°C	-	-	-	HQQE	HQQE	HQQE
Acetone, CH <sub>3</sub> COCH <sub>3</sub>	1, F	100%, +20°C	-	-	-	HQQE	HQQE	HQQE
Alkaline degreasing agent	D, F	-	HQQE	HQQE	HQQE	-	-	-
Ammonium bicarbonate, NH <sub>4</sub> HCO <sub>3</sub>	E	20%, +30°C	-	-	-	HQQE	HQQE	HQQE
Ammonium hydroxide, NH <sub>4</sub> OH	-	20%, +40°C	HQQE	HQQE	HQQE	-	-	-
Aviation fuel	1, 3, 4, F	100%, +20°C	HQBv	HQBv	HQBv	-	-	-
Benzoic acid, C <sub>6</sub> H <sub>5</sub> COOH	H	0.5%, +20°C	-	-	-	HQQV	HQQV	HQQV
Boiler water	-	<+120°C	HQQE	HQQE	HQQE	-	-	-
	F	+120°C - +180°C	-	-	-	-	-	-
Calcareous water	-	<+90°C	HQQE	HQQE	HQQE	-	-	-
Calcium acetate (as coolant with inhibitor) Ca(CH <sub>3</sub> COO) <sub>2</sub>	D, E	30%, +50°C	HQQE	HQQE	HQQE	-	-	-
Calcium hydroxide, Ca(OH) <sub>2</sub>	E	Saturated solution, +50°C	HQQE	HQQE	HQQE	-	-	-
Chloride-containing water	F	<+30°C, max. 500 ppm	-	-	-	HQQE	HQQE	HQQE
Chromic acid, H <sub>2</sub> CrO <sub>4</sub>	H	1%, +20°C	-	-	-	HQQV	HQQV	HQQV

# Pumped liquids

CR, CRI, CRN, CRE, CRIE, CRNE

Pumped liquid	Note	Liquid concentration, liquid temperature	CR(E), CRI(E)			CRN(E)		
			1s, 1, 3, 5	10, 15, 20	32, 45, 64, 90	1s, 1, 3, 5	10, 15, 20	32, 45, 64, 90
Citric acid, $\text{HOC}(\text{CH}_2\text{CO}_2\text{H})_2\text{COOH}$	H	5%, +40°C	-	-	-	HQQE	HQQE	HQQE
Completely desalinated water (demineralized water)	-	+120°C	-	-	-	HQQE	HQQE	HQQE
Condensate	-	120°C	HQQE	HQQE	HQQE	-	-	-
Copper sulfate, $\text{CuSO}_4$	E	10%, +50°C	-	-	-	HQQE	HQQE	HQQE
Corn oil	D, E, 3	100%, +80°C	HQQV	HQQV	HQQV	-	-	-
Diesel oil	2, 3, 4, F	100%, +20°C	HQBV	HQBV	HQBV	-	-	-
Domestic hot water (potable water)	-	<+120°C	HQQE	HQQE	HQQE	-	-	-
Ethanol (ethyl alcohol), $\text{C}_2\text{H}_5\text{OH}$	1, F	100%, +20°C	HQQE	HQQE	HQQE	-	-	-
Ethylene glycol, $\text{HOCH}_2\text{CH}_2\text{OH}$	D, E	50%, +50°C	HQQE	HQQE	HQQE	-	-	-
Formic acid, $\text{HCOOH}$	-	5%, +20°C	-	-	-	HQQE	HQQE	HQQE
Glycerine (glycerol), $\text{OHCH}_2\text{CH}(\text{OH})\text{CH}_2\text{OH}$	D, E	50%, +50°C	HQQE	HQQE	HQQE	-	-	-
Hydraulic oil (mineral)	E, 2, 3	100%, +100°C	HQQV	HQQV	HQQV	-	-	-
Hydraulic oil (synthetic)	E, 2, 3	100%, +100°C	HQQV	HQQV	HQQV	-	-	-
Isopropyl alcohol, $\text{CH}_3\text{CHOHCH}_3$	1, F	100%, +20°C	HQQE	HQQE	HQQE	-	-	-
Lactic acid, $\text{CH}_3\text{CH}(\text{OH})\text{COOH}$	E, H	10%, +20°C	-	-	-	HQQV	HQQV	HQQV
Linoleic acid, $\text{C}_{17}\text{H}_{31}\text{COOH}$	E, 3	100%, +20°C	HQQV	HQQV	HQQV	-	-	-
Methanol (methyl alcohol), $\text{CH}_3\text{OH}$	1, F	100%, +20°C	HQQE	HQQE	HQQE	-	-	-
Motor oil	E, 2, 3	100%, +80°C	HQQV	HQQV	HQQV	-	-	-
Naphthalene, $\text{C}_{10}\text{H}_8$	E, H	100%, +80°C	HQQV	HQQV	HQQV	-	-	-
Nitric acid, $\text{HNO}_3$	F	1%, +20°C	-	-	-	HQQE	HQQE	HQQE
Oil-containing water	-	<+100°C	HQQV	HQQV	HQQV	-	-	-
Olive oil	D, E, 3	100%, +80°C	HQQV	HQQV	HQQV	-	-	-
Oxalic acid, $(\text{COOH})_2$	H	1%, +20°C	-	-	-	HQQE	HQQE	HQQE
Ozone-containing water, ( $\text{O}_3$ )	-	<+100°C	-	-	-	HQQE	HQQE	HQQE
Peanut oil	D, E, 3	100%, +80°C	HQQV	HQQV	HQQV	-	-	-
Petrol	1, 3, 4, F	100%, +20°C	HQBV	HQBV	HQBV	-	-	-
Phosphoric acid, $\text{H}_3\text{PO}_4$	E	20%, +20°C	-	-	-	HQQE	HQQE	HQQE
Propanol, $\text{C}_3\text{H}_7\text{OH}$	1, F	100%, +20°C	HQQE	HQQE	HQQE	-	-	-
Propylene glycol, $\text{CH}_3\text{CH}(\text{OH})\text{CH}_2\text{OH}$	D, E	50%, +90°C	HQQE	HQQE	HQQE	-	-	-
Potassium carbonate, $\text{K}_2\text{CO}_3$	E	20%, +50°C	HQQE	HQQE	HQQE	-	-	-
Potassium formate (as coolant with inhibitor), $\text{KOOCH}$	D, E	30%, +50°C	HQQE	HQQE	HQQE	-	-	-
Potassium hydroxide, $\text{KOH}$	E	20%, +50°C	-	-	-	HQQE	HQQE	HQQE
Potassium permanganate, $\text{KMnO}_4$	-	5%, +20°C	-	-	-	HQQE	HQQE	HQQE
Rape seed oil	D, E, 3	100%, +80°C	HQQV	HQQV	HQQV	-	-	-
Salicylic acid, $\text{C}_6\text{H}_4(\text{OH})\text{COOH}$	H	0.1%, +20°C	-	-	-	HQQE	HQQE	HQQE
Silicone oil	E, 3	100%	HQQV	HQQV	HQQV	-	-	-
Sodium bicarbonate, $\text{NaHCO}_3$	E	10%, +60°C	-	-	-	HQQE	HQQE	HQQE
Sodium chloride (as coolant), $\text{NaCl}$	D, E	30%, <+5°C, pH>8	HQQE	HQQE	HQQE	-	-	-
Sodium hydroxide, $\text{NaOH}$	E	20%, +50°C	-	-	-	HQQE	HQQE	HQQE
Sodium hypochlorite, $\text{NaOCl}$	F	0.1%, +20°C	-	-	-	HQQV	HQQV	HQQV
Sodium nitrate, $\text{NaNO}_3$	E	10%, +60°C	-	-	-	HQQE	HQQE	HQQE
Sodium phosphate, $\text{Na}_3\text{PO}_4$	E, H	10%, +60°C	-	-	-	HQQE	HQQE	HQQE
Sodium sulfate, $\text{Na}_2\text{SO}_4$	E, H	10%, +60°C	-	-	-	HQQE	HQQE	HQQE
Softened water	-	<+120°C	-	-	-	HQQE	HQQE	HQQE
Soya oil	D, E, 3	100%, +80°C	HQQV	HQQV	HQQV	-	-	-
Sulfuric acid, $\text{H}_2\text{SO}_4$	F	1%, +20°C	-	-	-	HQQV	HQQV	HQQV
Sulfurous acid, $\text{H}_2\text{SO}_3$	-	1%, +20°C	-	-	-	HQQE	HQQE	HQQE
Unsalted swimming pool water	-	Approx. 2 ppm free chlorine ( $\text{Cl}_2$ )	HQQE	HQQE	HQQE	-	-	-

## Pipework connection

For pipework connection, various sets of counter flanges and couplings are available.

### Counter flanges for CR(E)

A set consists of one counter flange, one gasket, bolts and nuts.

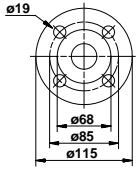
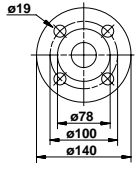
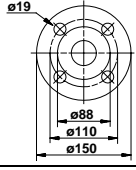
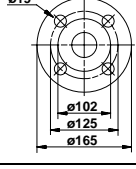
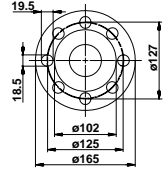
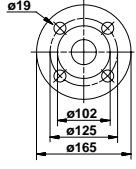
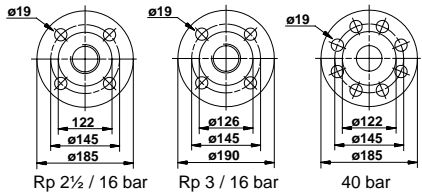
Counter flange	Pump type	Description	Rated pressure	Pipework connection	Product number	
	TM03 2115 3705	CR 1s CR(E) 1 CR(E) 3 CR(E) 5	Threaded	16 bar, EN 1092-2	Rp 1	409901
			For welding	25 bar, EN 1092-2	25 mm, nominal	409902
	TM03 0400 3705	CR 1s CR(E) 1 CR(E) 3 CR(E) 5	Threaded	16 bar, EN 1092-2	Rp 1½	419901
			For welding	25 bar, EN 1092-2	32 mm, nominal	419902
	TM03 0401 3705	CR(E) 10	Threaded	16 bar, EN 1092-2	Rp 1½	429902
			Threaded	16 bar, EN 1092-2	Rp 2	429904
			For welding	25 bar, EN 1092-2	40 mm, nominal	429901
			For welding	40 bar, special flange	50 mm, nominal	429903
	TM03 0402 3705		Threaded	16 bar, EN 1092-2	Rp 2	339903
			Threaded	16 bar, special flange	Rp 2½	339904
	TM02 7203 2803	CR(E) 15 CR(E) 20	Threaded	16 bar, special flange	Rp 2½ ★	96509578
	TM03 0402 3705		For welding	25 bar, EN 1092-2	50 mm, nominal	339901
			For welding	40 bar, special flange	65 mm, nominal	339902
	TM03 2116 3705	CR(E) 32	Threaded	16 bar, EN 1092-2	Rp 2½	349902
			Threaded	16 bar, special flange	Rp 3	349901
			For welding	16 bar, EN 1092-2	65 mm, nominal	349904
			For welding	40 bar, DIN 2635	65 mm, nominal	349905
			For welding	16 bar, special flange	80 mm, nominal	349903

Counter flange	Pump type	Description	Rated pressure	Pipework connection	Product number	
	TM03 2117 3705	Threaded	16 bar	Rp 3	350540	
		CR(E) 45	For welding	16 bar	80 mm, nominal	350541
		For welding	40 bar	80 mm, nominal	350542	
	TM03 2118 3705	Threaded	16 bar, EN 1092-2	Rp 4	369901	
		CR(E) 64 CR(E) 90	For welding	16 bar, EN 1092-2	100 mm, nominal	369902
		For welding	25 bar, EN 1092-2	100 mm, nominal	369905	

★ Flange with 20 mm higher collar. With this collar, the installation dimensions of a CR 20 will be identical to those of a CR 32.  
If a CR 32 is replaced with a CR 20, the base must be raised by 15 mm.

## Counter flanges for CRN(E)

Counterflanges for CRN(E) pumps are made of stainless steel according to EN 1.4401 (AISI 316).

A set consists of one counter flange, one gasket, bolts and nuts.

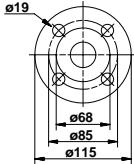
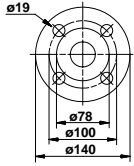
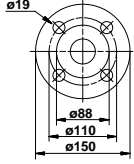
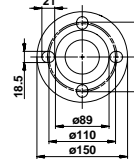
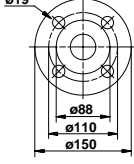
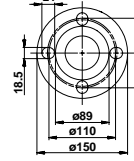
Counter flange	Pump type	Description	Rated pressure	Pipework connection	Product number
	TM03 2115 3705	Threaded	16 bar, EN 1092-2	Rp 1	405284
		CRI(E), CRN(E) 1s, 1, 3 and 5	For welding	25 bar, EN 1092-2	25 mm, nominal
	TM03 0400 3705	Threaded	16 bar, EN 1092-2	Rp 1¼	415304
		CRI(E), CRN(E) 1s, 1, 3 and 5	For welding	25 bar, EN 1092-2	32 mm, nominal
	TM03 0401 3705	Threaded	16 bar, EN 1092-2	Rp 1½	425245
	TM02 7202 2803	Threaded	16 bar, EN 1092-2	Rp 2	96509570
	TM03 0401 3705	For welding	25 bar, EN 1092-2	40 mm, nominal	425246
	TM02 7202 2803	For welding	25 bar, special flange	50 mm, nominal	96509571



Counter flange	Pump type	Description	Rated pressure	Pipework connection	Product number	
	TM00 0402 3705	Threaded	16 bar, EN 1092-2	Rp 2	335254	
	TM02 7203 2803	Threaded	16 bar, special flange	Rp 2½	96509575	
		Threaded	16 bar, special flange	Rp 2½ ★	96509579	
	TM03 0402 3705	For welding	25 bar, EN 1092-2	50 mm, nominal	335255	
			TM00 7203 2803	For welding	25 bar, special flange	65 mm, nominal
	TM03 2119 3705			CRN(E) 32	Threaded	16 bar
		Threaded	16 bar, special flange	Rp 3	349911	
		For welding	16 bar	65 mm, nominal	349906	
		For welding	40 bar	65 mm, nominal	349908	
		For welding	16 bar, special flange	80 mm, nominal	349907	
		For welding	25 bar, special flange	80 mm, nominal	349909	
	TM03 2117 3705	CRN(E) 45	Threaded	16 bar	Rp 3	350543
		For welding	16 bar	80 mm, nominal	350544	
		For welding	40 bar	80 mm, nominal	350545	
	TM03 2118 3705	CRN(E) 64 CRN(E) 90	Threaded	16 bar	Rp 4	369904
		For welding	16 bar	100 mm, nominal	369903	
		For welding	40 bar	100 mm, nominal	369906	

★ Flange with 20 mm higher collar. With this collar, the installation dimensions of a CR 20 will be identical to those of a CR 32.  
If a CR 32 is replaced with a CR 20, the base must be raised by 15 mm.

## PJE couplings for CRN(E)

Materials in contact with the pumped liquid are made of stainless steel EN 1.4401 (AISI 316) and rubber.

A set consists of two coupling halves (Victaulic type 77), one gasket, one pipe stud (for welding or threaded), bolts and nuts.

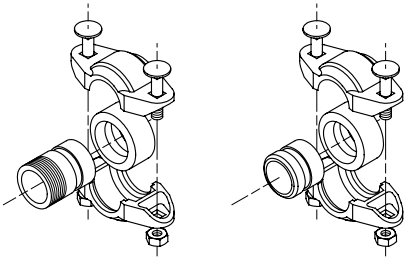
Coupling	Pump type	Pipe stub	PN	Pipework connection	Rubber parts	Number of coupling sets needed	Product number	
	<b>CRI(E), CRN(E) 1, 3 and 5</b>	Threaded	80 bar	R 1½	EPDM	2	419911	
					FKM	2	419905	
		For welding	80 bar	DN 32	EPDM	2	419912	
					FKM	2	419904	
		<b>CRI(E) CRN(E) 10, 15 and 20</b>	Threaded	70 bar	R 2	EPDM	2	339911
						FKM	2	339918
			For welding	70 bar	DN 50	EPDM	2	339910
						FKM	2	339917

TM00 3808 1094

## FlexiClamp base connections

All sets comprise the necessary number of bolts and nuts as well as a gasket/O-ring.

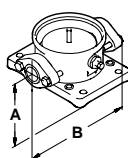
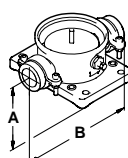
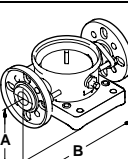
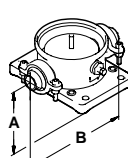
Base connection	Pump type	Connection	Pipework connection	A	B	Rubber parts	Number of coupling sets needed	Product number
	<b>CRI(E), CRN(E) 1, 3 and 5</b>	Oval (cast iron)	Rp 1	50	210	Klingsil	1	96449748
			Rp 1½			Klingsil	1	96449749
		Oval (stainless steel)	Rp 1	Klingsil	2	96449746		
			Rp 1½	Klingsil	2	96449747		
	<b>CRI(E), CRN(E) 1, 3 and 5</b>	Union	G 2	50	228	EPDM	2	96449743
						FKM	2	96449744
	<b>CRI(E), CRN(E) 1, 3 and 5</b>	DIN (stainless steel)	DN 25 DN 32	75	250	EPDM	2	96449745
						FKM	2	96449900
	<b>CRI(E), CRN(E) 1, 3 and 5</b>	Clamp, threaded pipe stub	Rp 1 Rp 1½ NPT 1 NPT 1½	50	208	EPDM	2	405280
						FKM	2	405281
						EPDM	2	415296
						FKM	2	415297
						EPDM	2	405291
						FKM	2	405292
						EPDM	2	415311
						FKM	2	415312
Clamp, pipe stub for welding	28.5	-	EPDM	2	405282			
	37.2	-	FKM	2	405283			
						EPDM	2	415300
						FKM	2	415301

TM02 7371 3303

TM02 7370 3303

TM02 7369 3303

TM02 7368 3303

# Accessories

CR, CRI, CRN, CRE, CRIE, CRNE

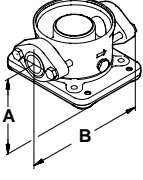
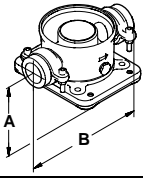
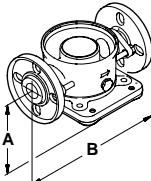
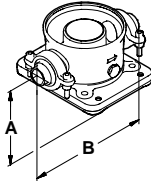
Base connection	Pump type	Connection	Pipework connection	A	B	Rubber parts	Number of coupling sets needed	Product number	
	TM02 7372 3303 <b>CRI(E) 10</b> <b>CRN(E) 10</b>	Oval (cast iron)	Rp 1¼	80	260	Klingersil	2	96498775	
			Rp 1½			Klingersil	2	96498727	
			Rp 2			Klingersil	2	96498836	
			Rp 1¼			Klingersil	2	96498776	
			Oval (stainless steel)			Rp 1½	Klingersil	2	96498728
			Rp 2			Klingersil	2	96498835	
	TM02 7374 3303 <b>CRI(E) 10</b> <b>CRN(E) 10</b>	Union	G 2¼	80	288	EPDM	2	96500275	
						FKM	2	96500276	
	TM02 7373 3303 <b>CRI(E) 10</b> <b>CRN(E) 10</b>	FGJ (cast iron)	DN 40	80	316	EPDM	2	96498840	
						FKM	2	96500119	
						FGJ (stainless steel)	EPDM	2	96500263
						FKM	2	96500264	
						FGJ (cast iron)	EPDM	2	96500265
						FKM	2	96500266	
	TM02 7375 3303 <b>CRI(E) 10</b> <b>CRN(E) 10</b>	Clamp, threaded pipe stub	Rp 1½  Rp 2  Rp 2½	80	346	EPDM	2	425238	
						FKM	2	425239	
						EPDM	2	335241	
						FKM	2	335242	
						EPDM	2	96508600	
						FKM	2	96508601	
Clamp, pipe stub for welding	TM02 7375 3303	48.3 (DN 40)  60.3 (DN 50)	-  -	-	-	EPDM	2	425242	
						FKM	2	425243	
						EPDM	2	335251	
						FKM	2	335252	

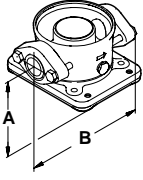
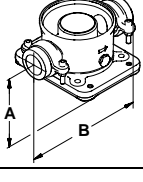
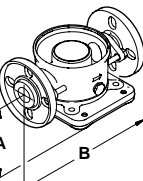
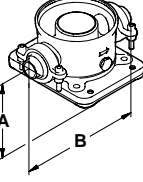
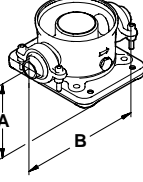
Base connection	Pump type	Connection	Pipework connection	A	B	Rubber parts	Number of coupling sets needed	Product number	
	TM02 7372 3303  <b>CRI(E) 15, 20 CRN(E) 15,20</b>	Oval (cast iron)	Rp 1¼	90	260	Klingersil	2	96498775	
			Rp 1½			Klingersil	2	96498727	
			Rp 2			Klingersil	2	96498836	
			Rp 1¼			Klingersil	2	96498776	
			Oval (stainless steel)			Rp 1½	Klingersil	2	96498728
			Rp 2			Klingersil	2	96498835	
	TM02 7374 3303  <b>CRI(E) 15, 20 CRN(E) 15,20</b>	Union	G 2¼	90	288	EPDM	2	96500275	
						FKM	2	96500276	
	TM02 7373 3303  <b>CRI(E) 15, 20 CRN(E) 15, 20</b>	FGJ (cast iron)	DN 40	90	334	EPDM	2	96498840	
						FKM	2	96500119	
						FGJ (stainless steel)	EPDM	2	96500263
						FKM	2	96500264	
						FGJ (cast iron)	EPDM	2	96500265
						FKM	2	96500266	
	TM02 7375 3303  <b>CRI(E) 15, 20 CRN(E) 15, 20</b>	Clamp, threaded pipe stub	Rp 1½   Rp 2   Rp 2½	90	346	EPDM	2	425238	
						FKM	2	425239	
						EPDM	2	335241	
						FKM	2	335242	
						EPDM	2	96508600	
						FKM	2	96508601	
	TM02 7375 3303  <b>CRI(E) 15, 20 CRN(E) 15, 20</b>	Clamp, pipe stub for welding	48.3 (DN 40)   60.3 (DN 50)	-	-	EPDM	2	425242	
						FKM	2	425243	
						EPDM	2	335251	
						FKM	2	335252	

## Potentiometer for CRE, CRIE, CRNE

Potentiometer for setpoint setting and start/stop of the CRE, CRIE, CRNE pump.

Product	Product number
External potentiometer with cabinet for wall mounting	625468

## G10-LON interface for CRE, CRIE, CRNE

The G10-LON interface is used in connection with data transmission between a Locally Operating Network (LON) and electronically controlled Grundfos pumps applying the Grundfos bus-protocol GENIbus.

Product	Product number
G10-LON interface	00605726

## LiqTec for CR(E), CRI(E) and CRN(E)

A dry-running protection device, the LiqTec protects pump and process against dry-running and temperatures exceeding 130°C ±5°C. Connected to the motor PTC sensor, LiqTec also monitors motor temperature.

LiqTec is prepared for DIN rail mounting in control cabinet.

Enclosure class: IP X0.

## Remote control, R100

R100 is used for wireless communication with the CRE, CRIE, CRNE pump. The communication takes place by means of infrared light.

Product	Product number
R100	625333

## EMC-filter for CRE, CRIE, CRNE

EMC-filter required for installation of 11 to 22 kW E-pumps in residential areas.

Product	Product number
EMC-filter (11 kW)	
EMC-filter (15 kW)	96478309
EMC-filter (18.5 kW)	
EMC-filter (22 kW)	

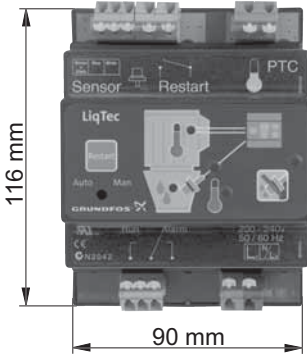
Dry-running protection	Pump type	Voltage [V]	LiqTec	Sensor ½"	Cable 5 m	Extension cable 15 m	Product number
	CR(E) CRI(E) CRN(E)	200-240	●	●	●	-	96556429
		80-130	●	●	●	-	96556430
		-	-	-	-	-	●

TM03 2108 3705

## Sensors for CRE, CRIE, CRNE

Accessory	Type	Supplier	Measuring range	Product number
Flowmeter	SITRANS FM MAGFLO MAG 5100 W	Siemens	1 - 5 m <sup>3</sup> (DN 25)	ID8285
Flowmeter	SITRANS FM MAGFLO MAG 5100 W	Siemens	3 - 10 m <sup>3</sup> (DN 40)	ID8286
Flowmeter	SITRANS FM MAGFLO MAG 5100 W	Siemens	6 - 30 m <sup>3</sup> (DN 65)	ID8287
Flowmeter	SITRANS FM MAGFLO MAG 5100 W	Siemens	20 - 75 m <sup>3</sup> (DN 100)	ID8288
Temperature sensor	TTA (0) 25	Carlo Gavazzi	0°C to +25°C	96432591
Temperature sensor	TTA (-25) 25	Carlo Gavazzi	-25°C to +25°C	96430194
Temperature sensor	TTA (50) 100	Carlo Gavazzi	+50°C to +100°C	96432592
Temperature sensor	TTA (0) 150	Carlo Gavazzi	0°C to +150°C	96430195
Accessory for temperature sensor. All with ½ RG connection	Protecting tube ø9 x 50 mm	Carlo Gavazzi		96430201
	Protecting tube ø9 x 100 mm	Carlo Gavazzi		96430202
	Cutting ring bush	Carlo Gavazzi		96430203
Temperature sensor, ambient temperature	WR 52	tmg (DK: Plesner)	-50°C to +50°C	ID8295
Differential temperature sensor	ETSD	Honsberg	0°C to +20°C	96409362
Differential temperature sensor	ETSD	Honsberg	0°C to +50°C	96409363

**Note:** All sensors have 4-20 mA signal output.

### Danfoss pressure sensor kits for CRE, CRIE, CRNE 1, 3, 5, 10, 15, 20, 32, 45, 64 and 90

Kit consisting of	Pressure range	Temperature range	Product number
<ul style="list-style-type: none"> <li>Danfoss pressure transmitter, type MBS 3000, with 2 m screened cable Connection: G ½ A (DIN 16288 - B6kt)</li> <li>5 cable clips (black)</li> <li>Instruction manual PT (00 40 02 12)</li> </ul>	0 - 4 bar	-40°C to +85°C	96428014
	0 - 6 bar		96428015
	0 - 10 bar		96428016
	0 - 16 bar		96428017
	0 - 25 bar		96428018

### HUBA differential pressure sensor kit

Kit consisting of..	Pressure range	Product number
<ul style="list-style-type: none"> <li>1 sensor incl. 1.5 m screened cable (7/16" connections)</li> </ul>	0 - 0.6 bar	485450
<ul style="list-style-type: none"> <li>1 original HUBA bracket (for wall mounting)</li> </ul>	0 - 1 bar	485441
<ul style="list-style-type: none"> <li>1 Grundfos bracket (for mounting on motor)</li> </ul>	0 - 1.6 bar	485442
<ul style="list-style-type: none"> <li>1 M6 screw (self-cutting) for mounting on MGE 90/100</li> </ul>	0 - 2.5 bar	485443
<ul style="list-style-type: none"> <li>1 M8 screw (self-cutting) for mounting on MGE 112/132</li> </ul>	0 - 4 bar	485444
<ul style="list-style-type: none"> <li>2 capillary tubes (short/long)</li> <li>2 brackets (1/4" - 7/16")</li> <li>5 cable clips (black)</li> </ul>	0 - 6 bar	485445

## Lists of variants - on request

Although the Grundfos CR(E), CRI(E), CRN(E) product range offers a number of pumps for different applications, customers require specific pump solutions to satisfy their needs.

Below please find the range of options available for customizing the CR(E) pumps to meet the customers' demands.

Contact Grundfos for further information or for requests other than the ones mentioned below.

### Motors

Variant	Description
<b>ATEX motor</b>	For operation in hazardous atmospheres, explosion-proof or dust-ignition-proof motors may be required.
<b>Motor with anti-condensation heating unit</b>	For operation in humid environments motors with built-in anti-condensation heating unit may be required.
<b>Motor with thermal protection</b>	Grundfos offers motors with built-in bimetallic thermal switches or temperature-controlled PTC sensors (thermistors) incorporated in the motor windings.
<b>Oversize motor</b>	Ambient temperatures above 40°C or installation at altitudes of more than 1000 metres above sea level require the use of an oversize motor (i.e. derating).
<b>4-pole motor</b>	Grundfos offers 4-pole standard motors.

### Shaft seals

Variant	Description
<b>Shaft seal with FFKM O-ring material</b>	Shaft seals with FFKM or FXM O-ring material are recommended for applications where the pumped liquid may damage the standard O-ring material.
<b>Seal with flush, quench seal</b>	Recommended for applications involving crystallizing, hardening or sticky liquids.
<b>Air-cooled shaft seal system</b>	Recommended for applications involving extremely high temperatures. No conventional mechanical shaft seal can withstand liquid temperatures of up to 180°C for any length of time. For such applications, Grundfos' unique air-cooled shaft seal system is recommended. In order to ensure a low liquid temperature around the standard shaft seal, the pump is fitted with a special air-cooled shaft seal chamber. No separate cooling is required.
<b>Double seal with pressure chamber</b>	Recommended for applications involving poisonous or explosive liquids. Protects the surrounding environment and the people working in the vicinity of the pump. Consists of two seals mounted in a "back-to-back" arrangement inside a separate pressure seal chamber. As the pressure in the chamber is higher than the pump pressure, leakage is prevented. A dosing pump or a special pressure-intensifier generates the seal chamber pressure.
<b>CR MAGdrive</b>	Magnetically driven pumps for industrial applications. Key applications are industrial processes involving the handling of aggressive, environmental, dangerous or volatile liquids, e.g. organic compounds, solvents, etc.

### Pumps

Variant	Description
<b>Horizontally mounted pump</b>	For safety or height reasons, certain applications, for instance on ships, require the pump to be mounted in the horizontal position. For easy installation the pump is equipped with brackets that support motor and pump.
<b>Low-temperature pump</b>	Exposed to temperatures down to -40°C, coolant pumps may require neck-rings with a different diameter in order to prevent impeller drag.
<b>High-speed pump up to 47 bar</b>	For high-pressure applications, Grundfos offers a unique pump capable of generating up to 47 bar. The pump is equipped with a high-speed motor, type MGE. The direction of rotation is the opposite of that of standard pumps, and the chamber stack is turned upside-down, as a result of which the pumped liquid flows in the opposite direction.
<b>High-pressure pump up to 47 bar</b>	For high-pressure applications, Grundfos offers a unique double pump system capable of generating a pressure of up to 47 bar pressure.
<b>Low-NPSH pump (improved suction)</b>	Recommended for boiler-feed applications where cavitation may occur due to poor inlet conditions.
<b>Pump with bearing flange</b>	The bearing flange is suitable for applications where the inlet pressure is higher than the maximum pressure recommended. The bearing flange increases the life of motor bearings. (Recommended for standard motors.)
<b>Belt-driven pump</b>	Belt-driven pumps designed to operate in places with limited space or where no electrical power is available.
<b>Pump for pharmaceutical and biotechnological applications</b>	CRN(E) pumps designed for applications requiring the sterilization and CIP capability of pipes, valves and pumps. (CIP = Cleaning-In-Place.)

### Connections and other variants

Variant	Description
<b>Pipe connections</b>	In addition to the wide range of standard flange connections, a 16 bar DIN standard clamping flange is available. Customized flanges are available according to specifications.
<b>TriClamp connection</b>	TriClamp connections are of a hygienic design with a sanitary coupling for use in the pharmaceutical and food industry.
<b>Electropolished pump</b>	To substantially reduce the risk of corrosion of the materials. For use in the pharmaceutical/food industry.

In addition to this printed data booklet, Grundfos offers the following sources of product documentation.

- WinCAPS
- WebCAPS.

## WinCAPS

WinCAPS is a **Windows-based Computer Aided Product Selection** program containing information on more than 90,000 Grundfos products.

Available on CD-ROM in more than 15 languages, WinCAPS offers

- detailed technical information
- selection of the optimum pump solution
- dimensional drawings of each pump
- detailed service documentation
- installation and operating instructions
- wiring diagrams of each pump.



Fig. 28 WinCAPS CD-ROM

cd-wincaps

Click **Catalogue** and select a product from the extensive product catalogue.

Click **Sizing** and select the most suitable pump for your application.

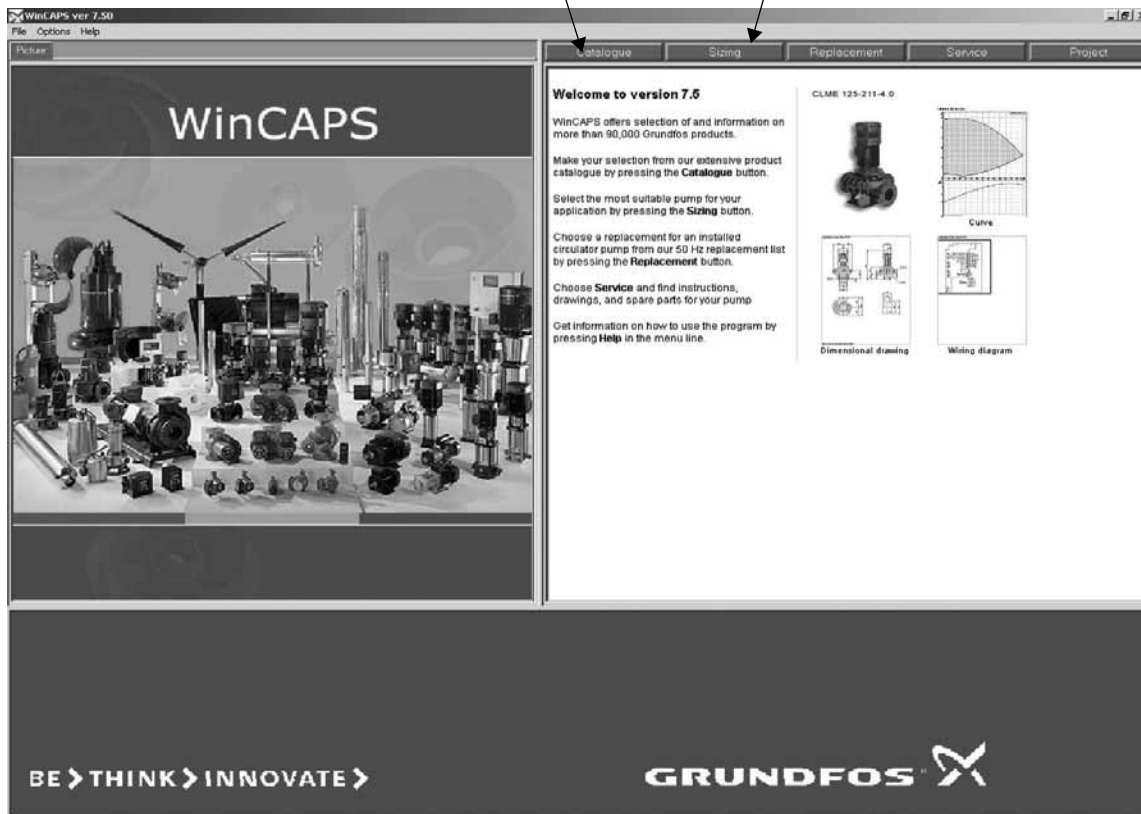

Fig. 29 WinCAPS

WinCAPS



## WebCAPS

WebCAPS is a **Web**-based **Compute Aided Product Selection** program and a web-version of WinCAPS.

WebCAPS is accessible on Grundfos' homepage, **www.grundfos.com**, and offers

- detailed technical information
- dimensional drawings of each pump
- wiring diagrams of each pump.

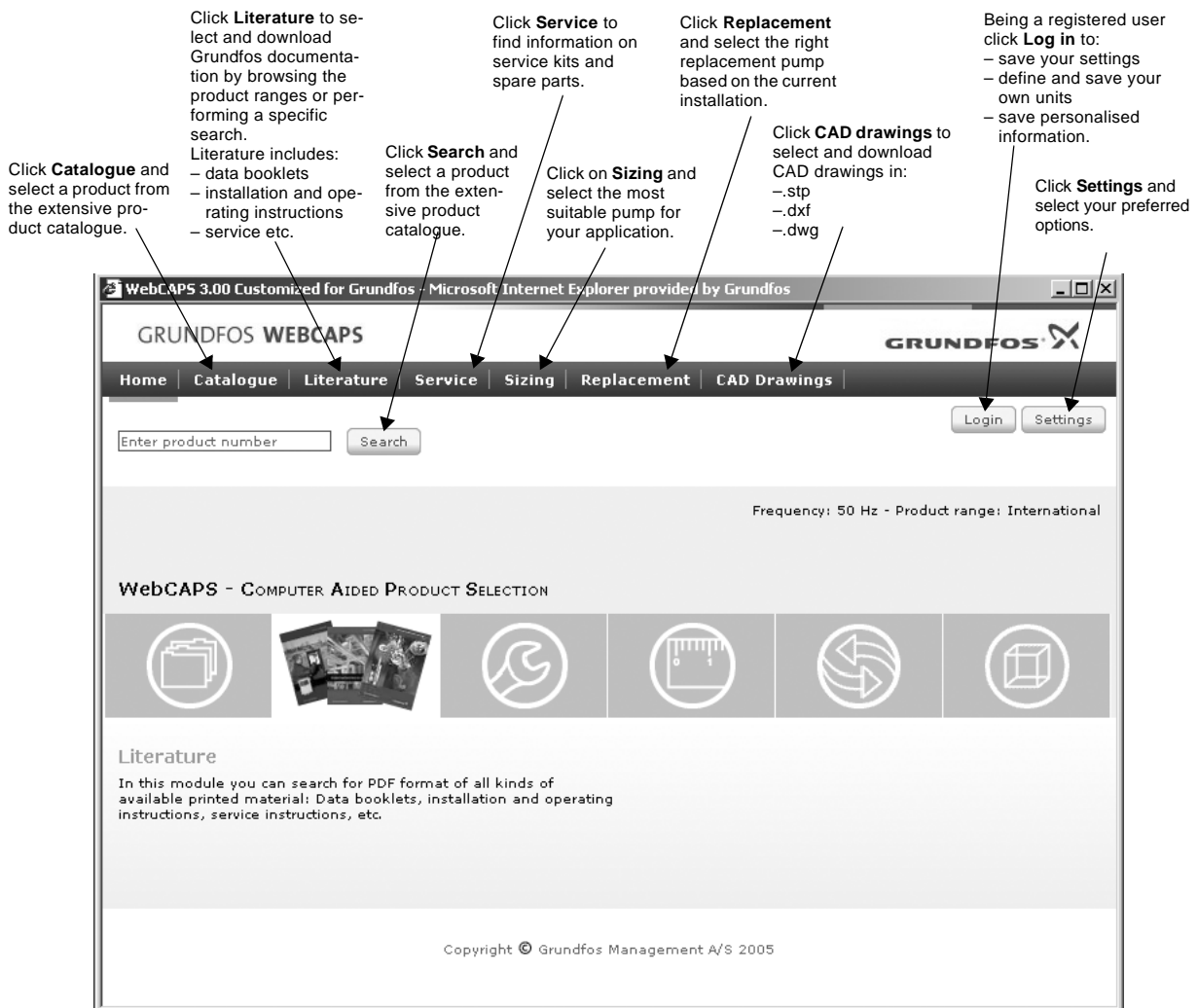

Fig. 30 WebCAPS

# Further product documentation

---

CR, CRI, CRN, CRE, CRIE, CRNE

# Further product documentation

---

CR, CRI, CRN, CRE, CRIE, CRNE

<b>V7023751</b> 1105	<b>GB</b>
Repl. V7023751 0105	

Subject to alterations.